

3D-magnet field probes - separate axis signals

AS-N3DM x+y+z syn-out

AS-L3DM x+y+z syn-out

AS-V3DM x+y+z syn-out



- separate measurement of X, Y and Z
- measurement of steady (DC) and alternating (AC) fields
- measurement range
 - AS-N3DM x+y+z syn-out: ± 2000 mT
 - AS-L3DM x+y+z syn-out: ± 200 mT
 - AS-V3DM x+y+z syn-out: ± 20 mT
- compact probe
6 x 6 x 100 mm³
- high bandwidth: DC – 10 kHz
- 3 separate analog outputs
- linearity error X, Y, Z
 - AS-N3DM x+y+z syn-out: $<0.5\% \pm 0.2$ mT
 - AS-L3DM x+y+z syn-out: $<0.5\% \pm 0.1$ mT
 - AS-V3DM x+y+z syn-out: $<0.5\% \pm 10$ μ T
- factory calibration certificate with traceability
- Made in Germany



The probes **AS-N3DM x+y+z syn-out**, **AS-L3DM x+y+z syn-out** and **AS-V3DM x+y+z syn-out** are 3-axis measurement systems, which allow to measure the three axes of the magnetic field. The measurement of the axes can be carried out separate of each other.

With the maximum measurement ranges of ± 2000 mT (**AS-N3DM x+y+z syn-out**), ± 200 mT (**AS-L3DM x+y+z syn-out**) or ± 20 mT (**AS-V3DM x+y+z syn-out**) respectively the probes are suitable for the measurement of strong as well as weaker magnetic fields.

The probes **AS-N3DM x+y+z syn-out**, **AS-L3DM x+y+z syn-out** and **AS-V3DM x+y+z syn-out** are compatible with the other probes from our program of AS-active-probes. Thereby they can be used with all devices which are intended to connect an AS-active-probe. The probes can be used together with the Teslameter FM 302 and the AS-Adapter 3.

The AS-active-probes are active measuring-probes for measuring magnetic flux density. In contrast to most other available probes, the AS-probes contain an active electronic so that a calibrated analog signal is available at the plug. These probes are premium transducers for measuring steady and alternating fields.

The 3-axis probes **AS-N3DM x+y+z syn-out**, **AS-L3DM x+y+z syn-out** and **AS-V3DM x+y+z syn-out** contain 3 sensors for the measurement of the 3 axis of the magnetic flux density within the probe head. With the dimension of merely 6 mm x 6 mm x 100 mm the probe head has a very compact size and is appropriate for the measurement even at small spaces.

For the simultaneous output of the single axis signals the probe cable is split into three probe connectors. Every probe connector contains the active electronic for the respective single axis.



With the three single axis probe connectors it is also necessary to use three single axis instruments or one 3-channel instrument to process the single axis signals delivered by the probes **AS-N3DM x+y+z syn-out**, **AS-L3DM x+y+z syn-out** and **AS-V3DM x+y+z syn-out**. The following devices from our program can be used:

- 3 pieces of Teslameter FM 302
- 1 piece of AS-Adapter 3

See also the chapters to the usage of the 3-axis AS-active-probes at page 14ff.

Every single axis of the probe behaves like a normal single axis probe. The full bandwidth of the probe is available. With the Teslameter FM 302 the constant component of the field (FM 302 – measurement mode DC) as well as the RMS-value of the alternating component (FM 302 – measurement mode AC) can be determined.

3-Axis Measurement

The probes **AS-N3DM x+y+z syn-out**, **AS-L3DM x+y+z syn-out** and **AS-V3DM x+y+z syn-out** just deliver the single axis signals.

Most available magnetic field probes are single axis probes. That means that they can only detect fields in parallel to their particular measurement direction. If the AS-probe is positioned with an angular to the field, the displayed value is lower than the actual field. The display value results from the following relation.

$$B_{display} = B_{real} \cdot \cos \alpha$$

To avoid this problem the **AS-N3DM x+y+z syn-out**, **AS-L3DM x+y+z syn-out** and **AS-V3DM x+y+z syn-out** are designed as 3D probes. There are three sensors mounted in the probe head which are aligned perpendicular to each other. These three sensors measure the three axes of the magnetic flux density.

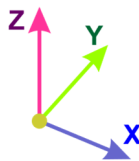

From the signals of the single axis the absolute value of the total signal can be calculated. The calculation is carried out according to the following formula.

$$B = \sqrt{B_x^2 + B_y^2 + B_z^2}$$

This principle works for all orientations between probe and magnetic field. Required is the perpendicularity of the single sensors.

Due to the high bandwidth of the probes even fast signals from DC to 10 kHz (AS-V3DM x+y+z syn-out 1 kHz) can be processed without problems.

Sign and Directional Information

The formula just calculates the magnitude of the field. The information about the direction of the magnetic field is not kept by the calculation. But it can be calculated separately by trigonometric formulas.

See also Measurement Direction and Polarity at page 4.

Constant Field Measurement with Overlaying Alternating Fields

The squaring of the values causes a rectifier effect. This rectification especially affects the measurement in the presence of alternating fields. Their rectified signal generates an additional constant component in the measurement signal and therefore an error in the measurement of constant fields.

If necessary, the single axis signals have to be filtered with low-pass filters in the external signal processing to achieve a sufficient suppression of overlaying alternating fields.

Measurement of Alternating Fields

If only the overlaying alternating field shall be measured, the constant component of every sensor axis has to be separated by a high-pass filter. Afterwards the calculation of the total field can be performed.

Also at the measurement of alternating fields the rectifying effect of the total field calculation has to be observed, too. To gather the effective value of the signal the processing has to be done from DC on.

Measurement Direction and Polarity

The single axis of the **AS-N3DM x+y+z syn-out**, **AS-L3DM x+y+z syn-out** and **AS-V3DM x+y+z syn-out** behave like a normal single axis probe. If in single axis measurement the probe is positioned with an angular to the field, the displayed value is lower than the actual field. The total field can be calculated from the measurement of all three single axis (see page 3).

Additionally, in single axis measurement the direction of the field is displayed by the sign of the measured value. The direction for a positive display value is indicated by the arrows of the axis at the probe head.



Mounting of the Probe Head

The body of the probe head consists of a square brass profile of 6 mm x 6 mm. For mounting the probe head can be e.g. clamped in an appropriate mounting hole.

The sensors are located at the front end of the probe head. Therefore, there should be applied no pressure at this area of the probe head.

The probe head must not be clamped at the first 20 mm.

Overload

The used sensors have a limited measurement range. Signals with more than ± 2500 mT at an **AS-N3DM x+y+z syn-out**, more than ± 250 mT at an **AS-L3DM x+y+z syn-out** or more than ± 25 mT at an **AS-V3DM x+y+z syn-out** will result in an overload of the single sensors. The entire field of alternating field and constant field has to be considered.

Constant field and alternating field may not overload the sensors. This would result in distort measurement results.

A damage of the sensors does not occur by the overload.

In case of doubt e.g. with complex alternating fields the signal should be checked with an oscilloscope at the analog output of the Teslometer FM 302 or AS-Adapter 3.

Minimum Required Field

The low end of the usable range is limited by non-linearity, offset error, zero drift, and noise. These values are stated in the technical data of the respective probe.

With the optionally available zero chamber (see page 12) an offset adjustment can be performed. This is especially advised before the measurement of small fields.

Heating due to Eddy Currents

When measuring fields of $B > 20$ mT and $f > 10$ kHz, the brass probe should not be operated for more than 1 minute in order to prevent excessive heating of the brass tube with the Hall elements inside!

Minimum Operation Conditions (EMC)

The presence of strong HF fields can result in distorted measurement results. A field strength of 3 V/m should not be exceeded.

Ground Connection / Earthing

The ground connections of the three probe connectors are connected with each other.

Attention should be paid that in the probe there is a connection between GND, probe head, connector shield, connector housing and cable. Possibly an isolated installation of the probe and/or the probe connector is necessary to prevent an unintended connection between measuring GND and protective earth.

Technical Data – 3-axis Probe 2000 mT (AS-N3DM x+y+z syn-out)

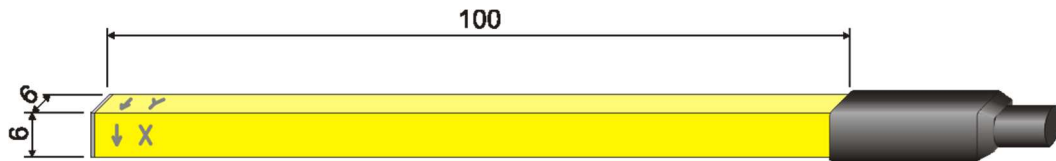

Transfer factor	
with FM 302	$\pm 2 \text{ V} / 20 \text{ mT}; \pm 2 \text{ V} / 200 \text{ mT}; \pm 2 \text{ V} / 2000 \text{ mT}$
with AS-Adapter 3	$\pm 10 \text{ V} / 200 \text{ mT}; \pm 10 \text{ V} / 2000 \text{ mT}$
Sensor volume	see drawing page 7
Effective sensor area	$< 0.1 \text{ mm}^2$ per axis
Perpendicularity of the sensors	$\pm 2^\circ$
Bandwidth (-3 dB)	DC – 10 kHz
Rise time (X, Y, Z)	$< 30 \mu\text{s}$
Linearity error (X, Y, Z)	$< 0.5 \% \pm 0.2 \text{ mT}$ (at $23^\circ\text{C} \pm 1^\circ\text{C}$)
Temperature coefficient (X, Y, Z)	max. $-0.05 \%/\text{K}$, typ. $-0.03 \%/\text{K}$ (0 to 50°C)
Zero drift (X, Y, Z)	max. $\pm 0.020 \text{ mT}/\text{K}$, typ. $\pm 0.010 \text{ mT}/\text{K}$ (DC)
Noise (X, Y, Z)	typ. $21 \mu\text{T}_{\text{RMS}}$ (10 Hz – 10 kHz) typ. $18 \mu\text{T}_{\text{PP}}$ (DC – 10 Hz, 50 s)
Probe head	brass 6 mm x 6 mm x 100 mm without cable transition and cable
Length of cable	1.5 m
Operation temperature	$+5^\circ\text{C}$ to $+50^\circ\text{C}$
Storage temperature	-10°C to $+60^\circ\text{C}$
Max. relative humidity	70 % at $+35^\circ\text{C}$
Power	$\pm 3 \text{ V}$ through FM 302, AS-Adapter 3 or PLC
Connector	15 pol. SubD
Output impedance	$< 1 \Omega$

typical linearity curves of the single axis

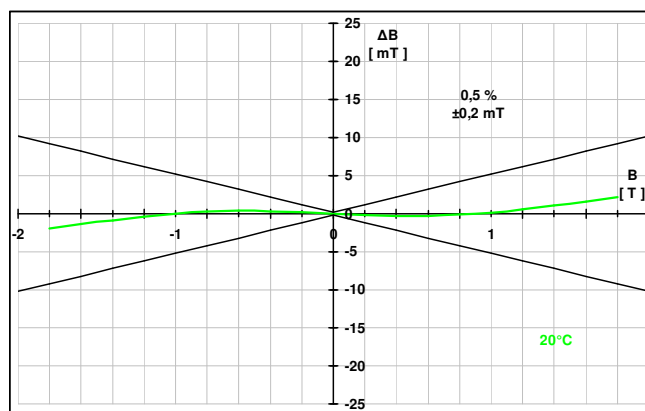

Position of the Active Areas AS-N3DM x+y+z syn-out

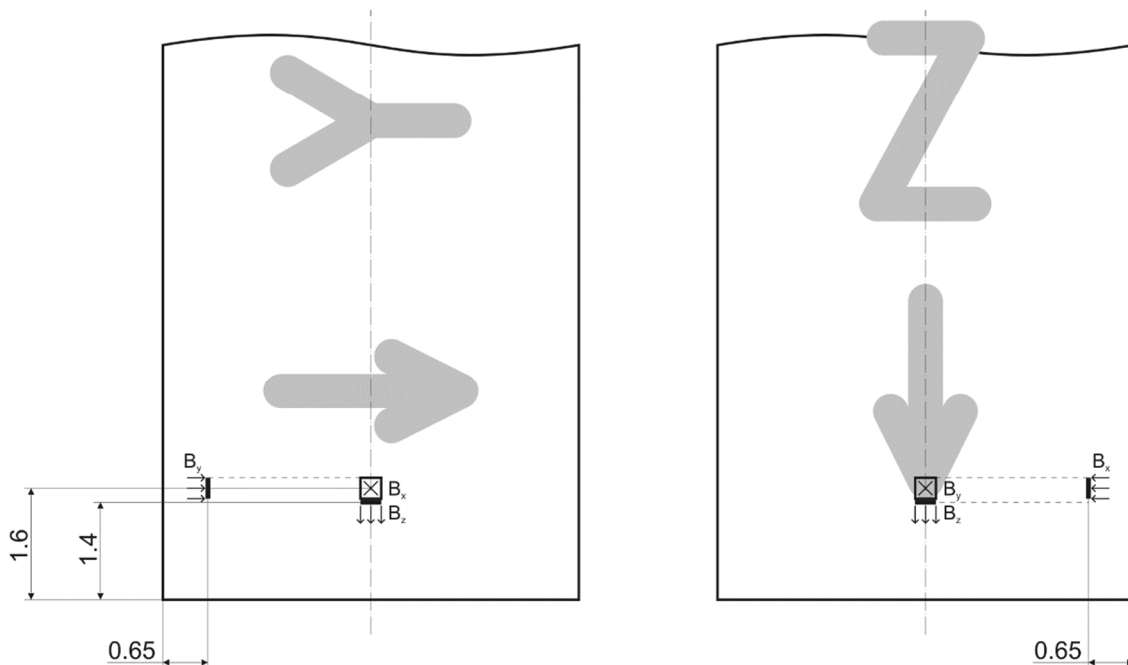
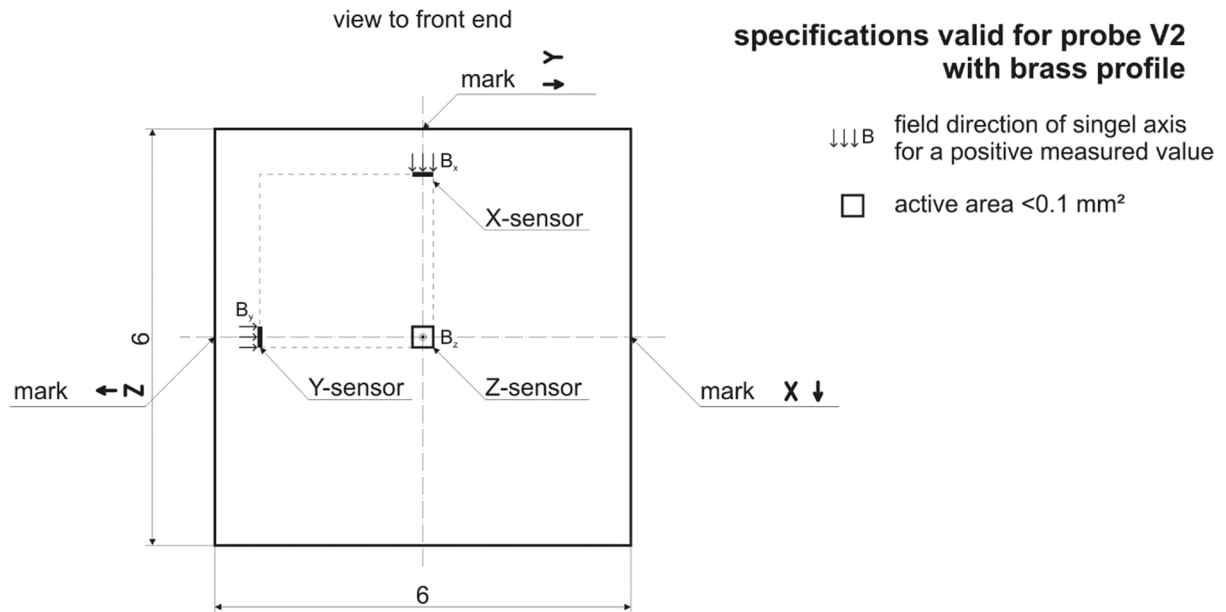

Technical Data – 3-axis probe 200 mT (AS-L3DM x+y+z syn-out)

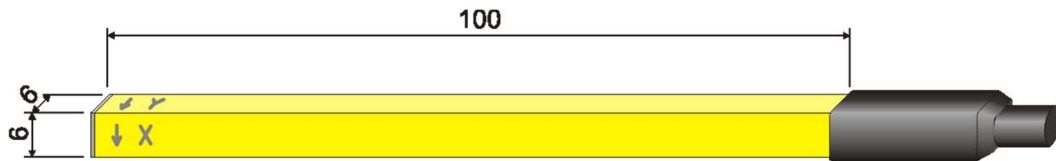

Transfer factor	
with FM 302	$\pm 2 \text{ V} / 2 \text{ mT}; \pm 2 \text{ V} / 20 \text{ mT}; \pm 2 \text{ V} / 200 \text{ mT}$
with AS-Adapter 3	$\pm 10 \text{ V} / 20 \text{ mT}; \pm 10 \text{ V} / 200 \text{ mT}$
Sensor volume	see drawing page 9
Effective sensor area	$< 0.1 \text{ mm}^2$ per axis
Perpendicularity of the sensors	$\pm 2^\circ$
Bandwidth (-3 dB)	DC – 10 kHz
Rise time (X, Y, Z)	$< 30 \mu\text{s}$
Linearity error (X, Y, Z)	$< 0.5 \% \pm 0.1 \text{ mT}$ (at $23^\circ\text{C} \pm 1^\circ\text{C}$)
Temperature coefficient (X, Y, Z)	max. $-0.05 \%/\text{K}$, typ. $-0.03 \%/\text{K}$ (0 to 50°C)
Zero drift (X, Y, Z)	max. $\pm 0.010 \text{ mT}/\text{K}$, typ. $\pm 0.005 \text{ mT}/\text{K}$ (DC)
Noise (X, Y, Z)	typ. $14 \mu\text{T}_{\text{RMS}}$ (10 Hz – 10 kHz) typ. $34 \mu\text{T}_{\text{PP}}$ (DC – 10 Hz, 50 s)
Probe head	brass 6 mm x 6 mm x 100 mm without cable transition and cable
Length of cable	1.5 m
Operation temperature	$+5^\circ\text{C}$ to $+50^\circ\text{C}$
Storage temperature	-10°C to $+60^\circ\text{C}$
Max. relative humidity	70 % at $+35^\circ\text{C}$
Power	$\pm 3 \text{ V}$ through FM 302, AS-Adapter 3 or PLC
Connector	15 pol. SubD
Output impedance	$< 1 \Omega$

typical linearity curves of the single axis

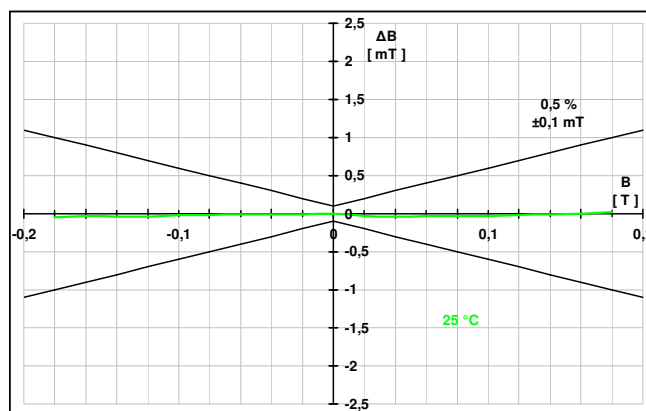

Position of the Active Areas AS-L3DM x+y+z syn-out

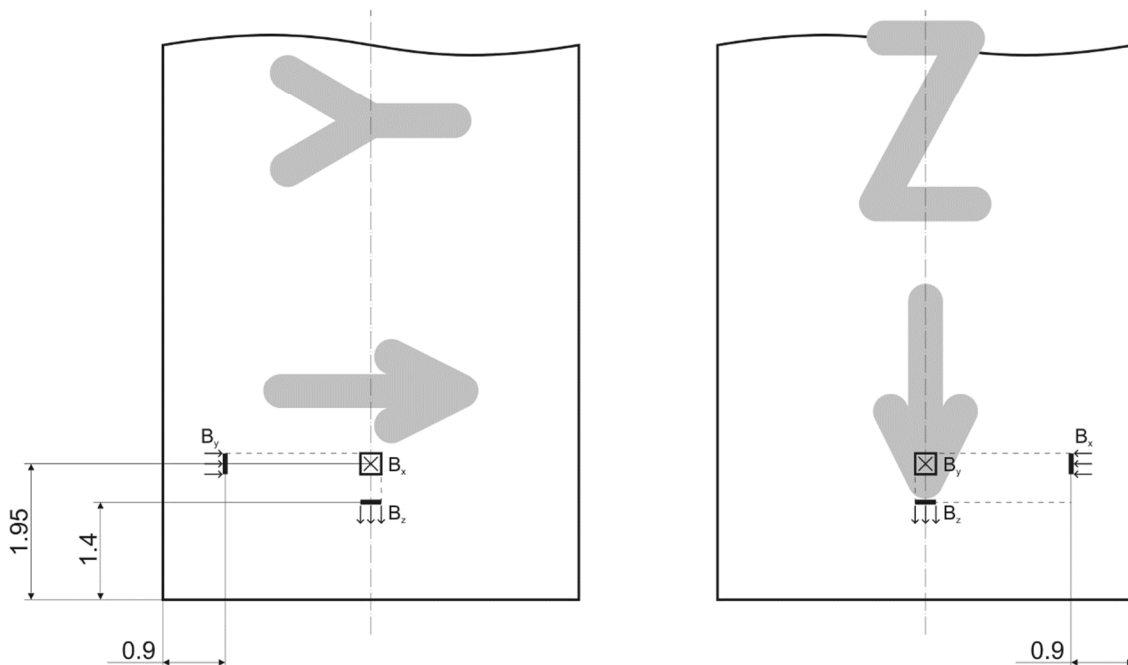
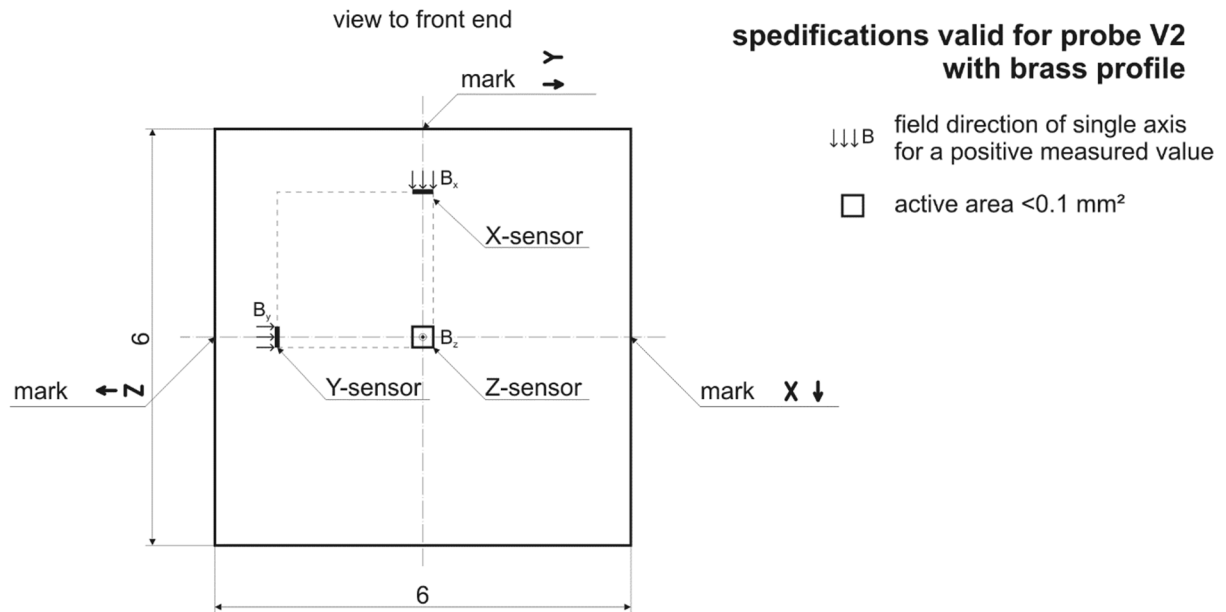

Technical Data – 3-axis probe 20 mT (AS-V3DM x+y+z syn-out)

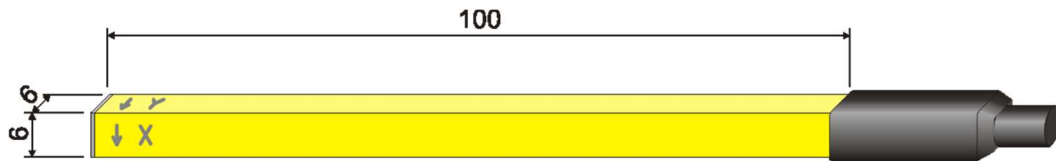

Transfer factor		
with FM 302		$\pm 2 \text{ V} / 200 \text{ } \mu\text{T}; \pm 2 \text{ V} / 2 \text{ mT}; \pm 2 \text{ V} / 20 \text{ mT}$
with AS-Adapter 3		$\pm 10 \text{ V} / 2 \text{ mT}; \pm 10 \text{ V} / 20 \text{ mT}$
Sensor volume		see drawing page 11
Effective sensor area		0.02 mm ² per axis
Perpendicularity of the sensors		$\pm 2^\circ$
Bandwidth (-3 dB)		DC – 1 kHz
Rise time (X, Y, Z)		<300 μs
Linearity error (X, Y, Z)		<0.5 % $\pm 10 \text{ } \mu\text{T}$ (at 23 °C $\pm 1 \text{ } ^\circ\text{C}$)
Temperature coefficient (X, Y, Z)		max. $\pm 0.06 \text{ } \%/ \text{K}$, typ. $\pm 0.03 \text{ } \%/ \text{K}$ (0 to 50 °C)
Zero drift (X, Y, Z)		max. $\pm 2 \text{ } \mu\text{T} / \text{K}$, typ. $\pm 1 \text{ } \mu\text{T} / \text{K}$ (DC)
Noise (X, Y, Z)		typ. 5 μT_{RMS} (10 Hz – 1 kHz) typ. 2 μT_{PP} (DC – 10 Hz, 50 s)
Probe head		brass 6 mm x 6 mm x 100 mm without cable transition and cable
Length of cable		1.5 m
Operation temperature		+5 °C to +50 °C
Storage temperature		-10 °C to +60 °C
Max. relative humidity		70 % at +35 °C
Power		$\pm 3 \text{ V}$ through FM 302, AS-Adapter 3 or PLC
Connector		15 pol. SubD
Output impedance		<1 Ω

typical linearity curves of the single axis

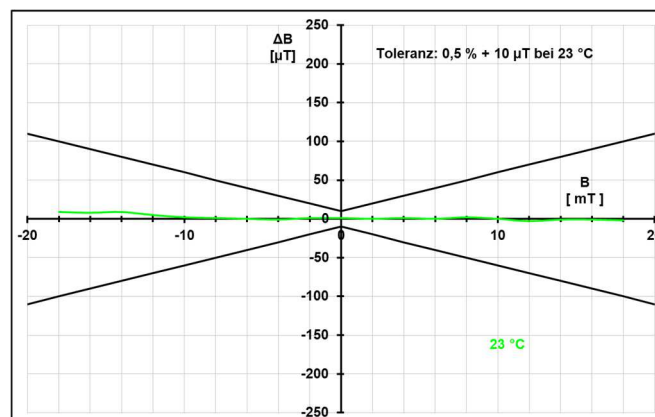

Position of the Active Areas AS-V3DM x+y+z syn-out

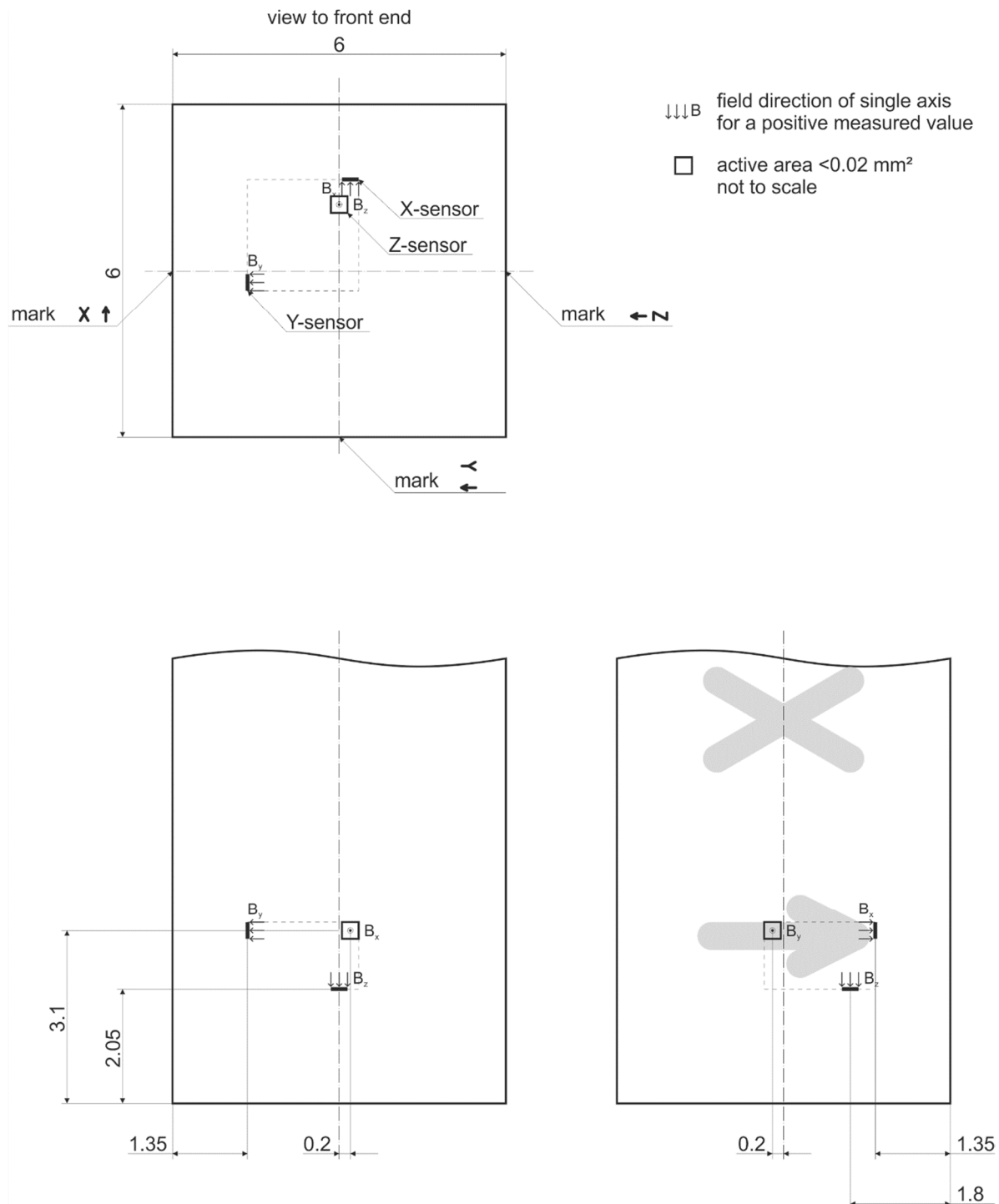

figure provisional

rotated compared to AS-N3DM x+y+z syn-out and AS-L3DM x+y+z syn-out

Devices to use with AS-active-probes

- **Teslameter FM 302**
device to use with one AS-active-probe
for further information see separate data sheet



- **AS-Adapter 3**
for simultaneous usage and supply of all 3 channels of 3-axis probe
for further information see separate data sheet



Usage of the 3-axis AS-active-probes with the Teslameter FM 302

For every of the three single axis a separate Teslameter FM 302 is necessary.

In normal case the plug of the probe electronic is simply connected to the Teslameter. The measurement can be started immediately.

Also all extended possibilities of the Teslameter FM 302 like calibrated analog output, control via USB interface or power supply with power adapter are usable in that way.

For the connection with a computer an USB cable is necessary for every of the three Teslameter FM 302. These are included in delivery of the Teslameter FM 302. At the computer there will be a separate virtual serial port for every device.

The Teslameter FM 302 offers the opportunity to switch the sensitivity between x1, x10 and x100. Thus with every probe a wide measuring range can be covered. Furthermore the Teslameter FM 302 offers switching of the display unit.

Also see our webpage about sensitivity classes

<http://www.projekt-elektronik.de/teslameter-gaussmeter/magnetfeldsonden-as-aktivsonden/empfindlichkeitsklassen/>

Further details can be found in the data sheet of the Teslameter FM 302.

Usage of the 3-axis AS-active-probes with the AS-Adapter 3

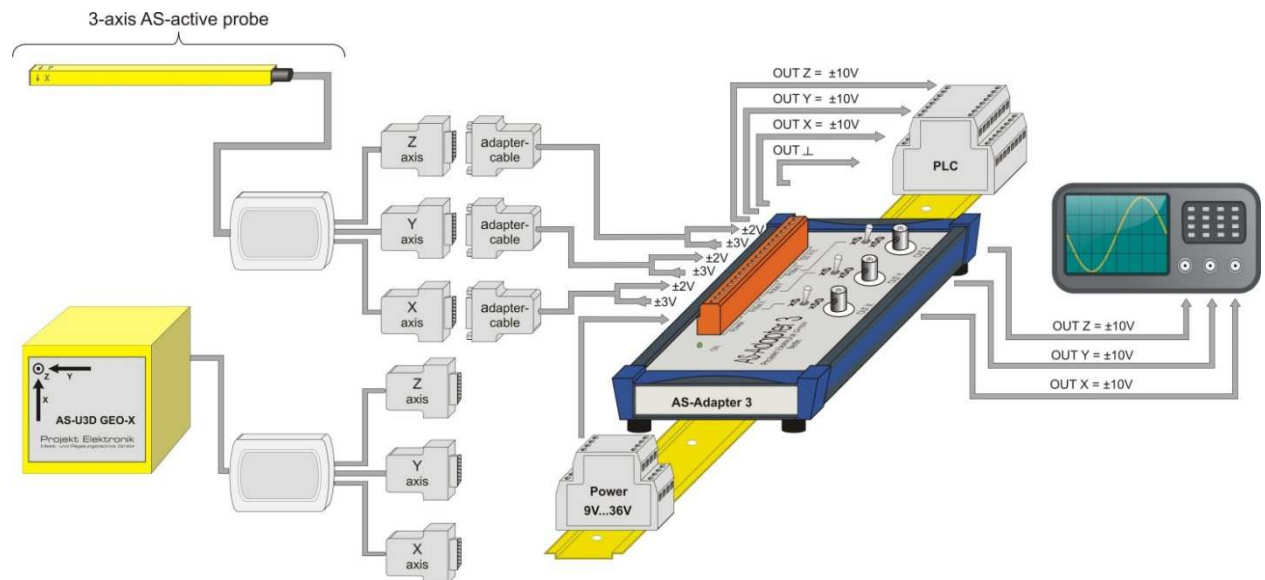

The AS-Adapter 3 offers three measurement channels in a single device. Hence, for the three probe connectors of the single axes only one AS-Adapter 3 is required.

The AS-Adapter 3 amplifies the analog output signal of the probes to $\pm 10\text{ V}$ (gain x5) which is the typical input range of analog inputs of a PLC.

With the switch at the AS-Adapter 3 a 10-times higher gain (x50) can be selected. This way, even small fields can be measured in this configuration.

To be usable all-purpose the AS-Adapter 3 has a wide supply voltage range from 9 V to 36 V and provides high-stable ± 3 V necessary to supply the AS-active-probes. Additionally, the measurement signal is galvanically isolated from the power supply.

The analog output signals from all 3 single axes are available simultaneously and in parallel up to full bandwidth of the probes via the BNC connections or via respective the terminal contacts.

Further details can be found in the data sheet of the AS-Adapter 3.

Winding up of Cables

Cables always should be wound up in a way that no knots or twists occur. To ease you the winding up of the cable we have collected and mentioned below some instructions available on the Internet.

- <https://www.youtube.com/watch?v=0yPcJD7RVuY>
- <https://www.youtube.com/watch?v=pEd7ru24Vx0>
- <https://www.youtube.com/watch?v=3j1Wdc-ymbI>
- <https://www.popularmechanics.com/technology/how-to/tips/a-solution-for-tangled-headphones-15413257>

Application Notes

On our website (<http://www.projekt-elektronik.com/applikation.php>) under Application you can find many additional documents with information, hints and examples about the measurement of magnetic fields.

Consulting and customization

We gladly stand at your disposal for questions about measuring tasks, manufacturing of probes, changing of measurement range, bandwidth or similar via telephone or email.

Your PE - Team