

AS-active-probes

- Calibrated probes for nT-, μ T-, mT- and T- range
- High precision
- Analog output: DC – 35 kHz (depending on probe type)
- operation as autonomous transducer
- thin and flexible probes
- factory calibration certificate with traceability
- as manufacturer we have this probes on stock and therefore short delivery time
- Made in Germany

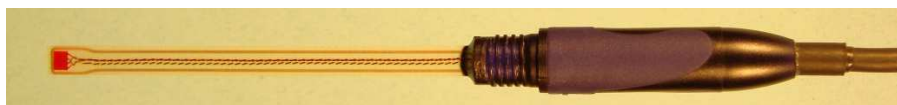

AS-NTP 0,6 thin transverse probe



AS-NTM, AS-NTM-2 and AS-LTM transverse probe brass



AS-NAP, AS-LAP and AS-HAP axial probe



AS-NTP-Hot-05 transverse probe for high and low temperature

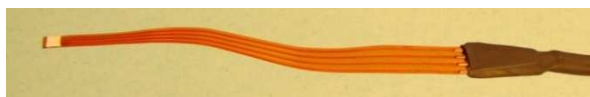

AS-NTP-Flex flexible transverse probe



AS-NTP-Flex 0,6 flexible transverse probe



AS-VTP transverse probe for small fields



AS-NCu-Wire transverse probe

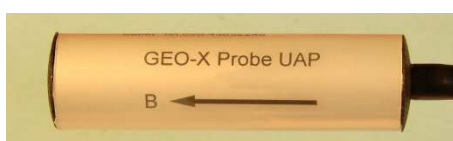

AS-UAP GEO-X probe



AS-UAP Lot probe

The AS-active-probes are active measuring-probes for measuring magnetic flux density. In contrast to most other available probes, the AS-probes contain an active electronic so that a calibrated analog signal is available at the plug. These probes are premium transducers for measuring steady and alternating magnetic fields.

The probes can be used with the Teslometer FM 302, AS-probe adapter, AS-Adapter 3 or as autonomous transducers in data acquisition systems.

The transverse probe made of glass fiber fabric (AS-NTP 0,6) with their slight thickness makes it possible to measure in narrow air gaps and difficult-to-reach locations. For transportation the probe is protected by a cap. Furthermore the probe carrier is temperature resistant up to 100 °C.

For rough operating conditions the transverse probe is provided in a design with brass protective tube (AS-NTM, AS-LTM). However they are thicker than the AS-NTP 0,6.

The transverse probes AS-NTP-Flex and AS-NTP-Flex 0,6 are made with a strip of very thin, extreme flexible and bendable material. They are qualified to measure remarkable hard to reach locations and smallest air gaps. Furthermore the probe carrier is temperature resistant up to 100 °C at the AS-NTP-Flex and even up to 150 °C at the AS-NTP-Flex 0,6.

The transverse AS-VTP is suitable especially for the measurement of small fields. It qualifies due to their small zero drift and their low noise.

The probe AS-NCu-Wire is an extra thin sensor connected with very light wires. Thus the probe is suited to measure at closed quarters and to mount into complex measurement setups.

At very high demands to accuracy and temperature stability the probe AS-NTM-2 may be used. Linearity error and temperature drift have been highly reduced compared to the other probes.

The transverse high-temperature probe AS-NTP-Hot-05 is designed to measure even at high temperatures up to 150 °C and at low temperatures down to -40 °C. The probe itself and the probe cable are constructed to permanently endure those temperatures.

The also available axial probes (AS-LAP, AS-NAP, AS-HAP) have a small diameter and thus are suitable to measure fields in small coils.

With the axial AS-UAP probes particularly small fields can be measured with a resolution down to one nano Tesla. Furthermore it has the facility to compensate $\pm 70 \mu\text{T}$ which for example provides the possibility to compensate the earth magnetic field. So only differences are measured which can be done with higher resolution.

The AS-UAP probe is available in two types. The AS-UAP GEO-X probe is suitable for general measuring tasks while the AS-UAP Lot probe with their special plummet housing with weighted tip is mainly suitable for measuring the vertical component of the earth magnetic field.

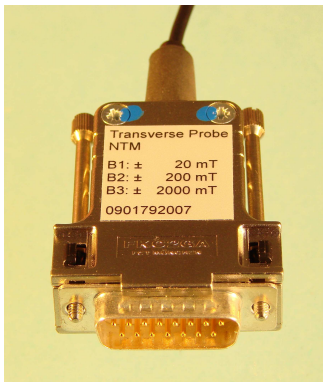

probe plug normal



probe plug UAP
± 70 µT compensation
can be additionally activated

Included in delivery:

- AS-active-probe
- manual
- factory calibration certificate with traceability

Options:

- **probe extension cord**
2 m, 5 m or 10 m
without influence on measurement result
- **zero chamber**
for shielding external fields and for exact offset adjustment
see Application Note PE012 – Zero Chamber – Zero Point Adjustment



- **test curve / linearity curve**
test curve at max. five temperatures, every with 19 test points
see Application Note PE003 – Linearity Curves
for typical curves see the technical data of the probes

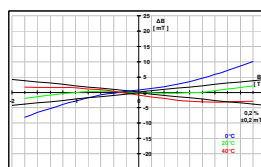

Devices to use with AS-active-probes

- **Teslameter FM 302**
device to use with one AS-active-probe
for further information see separate data sheet



- **AS-probe adapter**
for usage and supply of one AS-active-probe e.g. at PLC
for further information see separate data sheet



- **AS-Adapter 3**
for simultaneous usage and supply of up to 3 AS-active-probe
for further information see separate data sheet



Sensitivity Classes – Overview

Every AS-active-probe delivers a calibrated, analog output signal whose level depends on the measured field. Our probes are offered in different sensitivity classes. Table 1 shows the measuring ranges and transfer factors in dependence of the class.

class	range probe without Teslameter			transfer factor probe
High:	⁽¹⁾ 20 T	200 kG	15,92 MA/m	2 V / 20 T ⁽¹⁾
Normal:	2 T	20 kG	1592 kA/m	2 V / 2 T
Low:	0,2 T	2 kG	159,2 kA/m	2 V / 0,2 T
Verylow:	20 mT	200 G	15,92 kA/m	2 V / 20 mT
Ultralow:	200 µT	2 G	159,2 A/m	2 V / 200 µT

Table 1

The Teslameter FM 302 offers the opportunity to switch the gain between x1, x10 and x100. Thus with every probe a wide measuring range can be covered. Furthermore the Teslameter FM 302 offers switching of the display unit. Table 2 shows the resulting measuring ranges and the transfer factors for the analog output.

class	ranges and transfer factors with Teslameter FM 302 (FM 205) range x1, x10, x100					
High:	x1	⁽¹⁾ 20 T	200 kG	200 kOe	15,92 MA/m	2 V / 20 T
	x10	2 T	20 kG	20 kOe	1592 kA/m	2 V / 2 T
	x100	0,2 T	2 kG	2 kOe	159,2 kA/m	2 V / 0,2 T
Normal:	x1	2000 mT	20 kG	20 kOe	1592 kA/m	2 V / 2000 mT
	x10	200 mT	2 kG	2 kOe	159,2 kA/m	2 V / 200 mT
	x100	20 mT	0,2 kG	0,2 kOe	15,92 kA/m	2 V / 20 mT
Low:	x1	200 mT	2000 G	2000 Oe	159,2 kA/m	2 V / 200 mT
	x10	20 mT	200 G	200 Oe	15,92 kA/m	2 V / 20 mT
	x100	2 mT	20 G	20 Oe	1,592 kA/m	2 V / 2 mT
Verylow:	x1	20 mT	200 G	200 Oe	15,92 kA/m	2 V / 20 mT
	x10	2 mT	20 G	20 Oe	1,592 kA/m	2 V / 2 mT
	x100	200 µT	2 G	2 Oe	159,2 A/m	2 V / 200 µT
Ultralow:	x1	200 µT	2 G	2 Oe	159,2 A/m	2 V / 200 µT
	x10	20 µT	200 mG	200 mOe	15,92 A/m	2 V / 20 µT
	x100	2 µT	20 mG	20 mOe	1,592 A/m	2 V / 2 µT

Table 2

(1) calibrated up to 12 T

Units T - Tesla G - Gauss Oe - Oersted A/m - Ampere per Meter
For conversion of magnetic units see our application note "PE005 –Magnetic units of measurement and their conversion".

To ease the connection of the AS-active probe to existing analog inputs with ± 10 V input range, the AS-probe adapter contains an integrated amplifier. This amplifies the output signal of the AS-active probes from ± 2 V to ± 10 V. With a switch, an additionally 10times higher gain can be chosen which allows to perform even sensitive measurements.

Table 3 shows the measurement ranges as well as the transfer factors for the analog output resulting from the different probes.

class	ranges and transfer factors with AS-probe adapter range x5, x50		
High:	x5	⁽¹⁾ 20 T	10 V / 20 T
	x50	2 T	10 V / 2 T
Normal:	x5	2000 mT	10 V / 2000 mT
	x50	200 mT	10 V / 200 mT
Low:	x5	200 mT	10 V / 200 mT
	x50	20 mT	10 V / 20 mT
Verylow:	x5	20 mT	10 V / 20 mT
	x50	2 mT	10 V / 2 mT
Ultralow:	x5	200 μ T	10 V / 200 μ T
	x50	20 μ T	10 V / 20 μ T

Table 3

(1) calibrated up to 12 T

Measurement Direction

The AS-active-probes are as system of single axis probes. This means that they can detect fields in parallel to their measuring direction. If the probe is positioned to the field with an angle the measured value is lower than the actual field.

AS-active-probes are available both as transverse and axial types.

Transverse probes have the shape of a flat stem. They measure the field which perpendicular enters the probe. At these probes there are versions with brass stem available to achieve a higher rigidity.

The axial probes are in shape of a round pole. Here the field is measured in the direction of the pole.

type

T	transverse probe
T-Ms	brass transverse probe for heavy duty usage
A	axial probe

Table 4

The following images show how the field of a permanent magnet and the field of a coil can be measured with both types of probes.

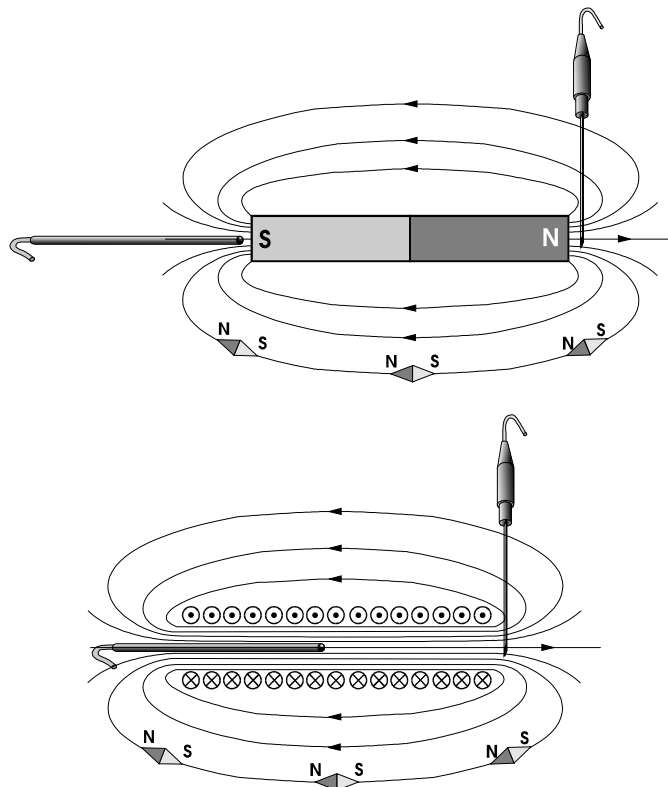

AS-active-probes – Overview Normal

For most application our AS-active-probe of class normal are suited. The fields typically occurring in technical areas can be measured with these probes.

class	model	type	linearity error ⁽²⁾	thickness mm	operation temp. °C	application
Normal:	AS-NTP 0,6	T	< 0.5 % ±0.2 mT	0.6 ± 0.1	5 – 100 ⁽⁴⁾	- air gap - relay
	AS-NTM	T-Ms	< 0.2 % ±0.2 mT	1.4 ± 0.1	5 – 50	- magnets, E-motors - SmCo, NdFeB, AlNiCo
	AS-NTM-2	T-Ms	< 0.05% ±0.2 mT	1.4 ± 0.1	5 – 50	- magnets, E-motors - SmCo, NdFeB, AlNiCo
	AS-NAP	A	< 0.5 % ±0.2 mT	Ø 6.0	5 – 50	- air coils
	AS-NTP-Hot-05	T	< 0.2 % ±0.2 mT	1.5 ± 0.1	-40 – 150 ⁽³⁾	- low temperatures - high temperatures
	AS-NTP-Flex	T	< 0.5 % ±0.2 mT up to 1.5 T	0.6 ± 0.1	5 – 100 ⁽⁴⁾	- flexible and thin
	AS-NTP-Flex 0,6	T	< 0.5 % ±0.2 mT	0.6 ± 0.1	5 – 150 ⁽⁷⁾	- flexible and thin
	AS-NCu-Wire	T	< 0.5 % ±0,2 mT up to 1.5 T	0.6 ± 0.1	5 – 100 ⁽⁵⁾	- very thin

Table 5

(2) at +20 °C or +25 °C

(3) probe, handle and cable = -40 °C to +150 °C; probe plug = +5 °C to +50 °C

(4) at first 70 mm = +5 °C to +100 °C; handle, cable and probe plug = +5 °C to +50 °C

(5) at first 150 mm = +5 °C to +100 °C; handle, cable and probe plug = +5 °C to +50 °C

(7) at first 70 mm = +5 °C to +150 °C; handle, cable and probe plug = +5 °C to +50 °C

AS-active-probes – Overview Earth Magnetic Field

For the measurement of very small fields like e.g. the earth magnetic field we offer our probes of class Ultralow. With the possibility of compensation of ±70 µT the overlaying earth magnetic field can be masked. So even very small stray and noise fields can be measured with this probes.

class	model	type	linearity error ⁽²⁾	thickness mm	operation temp. °C	application
Ultralow:	AS-UAP Geo-X	A	< 0.8 % ±0.2 µT	Ø 17	5 – 50	- geomagnetism - weak fields - IATA 953 (former 902)
	AS-UAP Lot	A	< 0.8 % ±0.2 µT	Ø 18.8	5 – 50	- geomagnetism - weak fields

Table 6

(2) at +20 °C or +25 °C

AS-active-probes – Overview High Field

Especially for the measurement of very high field the probe AS-HAP of class High has been developed. Such high permanent fields are normally only achieved with superconductors. Temporary they can be generated with other setups, too.

class	model	type	linearity error ⁽²⁾	thickness mm	operation temp. °C	application
High:	AS-HAP	A	< 2.0 % ±20 mT	Ø 6.4	5 – 50	- MRT - superconductors

Table 7

(2) at +20 °C or +25 °C

AS-active-probes – Overview Low Field

If only small fields shall be measured, also the probes of class Low can be used.

class	model	type	linearity error ⁽²⁾	thickness mm	operation temp. °C	application
Low:	AS-LTM	T-Ms	< 0.2 % ±0.1 mT	1.4 ± 0.1	5 – 50	- residual magnetism - Helmholtz coils - magnetic sheets - limit values
	AS-LAP	A	< 0.5 % ±0.1 mT	Ø 6.0	5 – 50	- residual magnetism - Helmholtz coils - magnetic sheets - limit values

Table 8

(2) at +20 °C or +25 °C

AS-active-probes – Overview Very Low Field

For even smaller fields, probes of class verylow can be used. Typically, they are used to measure residual magnetism at produced parts or to control compliance with limit values (e.g. employee safety, pacemaker)

class	model	type	linearity error ⁽⁸⁾	thickness mm	operation temp. °C	application
Verylow:	AS-VTP	T	< 0.5 % ±10 µT	1.3 ± 0.1	5 – 50	- residual magnetism - Helmholtz coils - limit values

Table 9

(8) at +23 °C

AS-active-probes – Overview Further Data

class	model	bandwidth (-3 dB)	active area	temperature coefficient or. error
High:	AS-HAP	DC – 35 kHz	0.2 mm ²	-0.05 %/K
Normal:	AS-NTP 0,6	DC – 35 kHz	0.2 mm ²	-0.03 %/K
	AS-NTM	DC – 25 kHz	0.2 mm ²	-0.03 %/K
	AS-NTM-2	DC – 25 kHz	0.12 mm ²	±0,005 %/K
	AS-NAP	DC – 35 kHz	0.2 mm ²	-0.03 %/K
	AS-NTP-Hot-05	DC – 35 kHz	0.5 mm ²	±1.0 % ±0.2 mT ⁽⁶⁾
	AS-NTP-Flex	DC – 0.5 kHz	2 mm ²	-0.03 %/K
	AS-NTP-Flex 0,6	DC – 35 kHz	0.2 mm ²	-0.03 %/K
	AS-NCu-Wire	DC – 35 kHz	2 mm ²	-0.03 %/K
	Low:	AS-LTM	DC – 10 kHz	0.2 mm ²
AS-LAP		DC – 10 kHz	0.2 mm ²	-0.03 %/K
Verylow:	AS-VTP	DC – 1 kHz	0.02 mm ²	±0.03 %/K
Ultralow:	AS-UAP Geo-X	DC – 0.5 kHz	Ø 5 mm x 22 mm	±0.1 %/K
	AS-UAP Lot	DC – 0.5 kHz	Ø 5 mm x 22 mm	±0.1 %/K

Table 10

(6) in range of -10 °C to +150 °C

Comparison AS-active-probes

In the following there are put together the typical test curves / linearity curves of some probes for comparison.

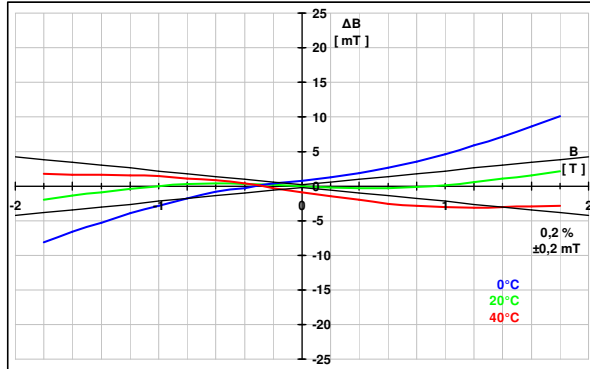

AS-NTM

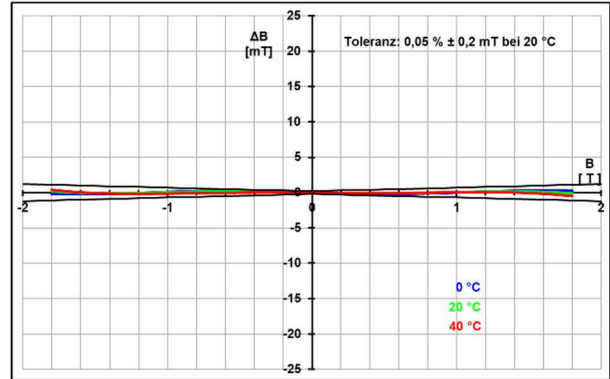

AS-NTM-2

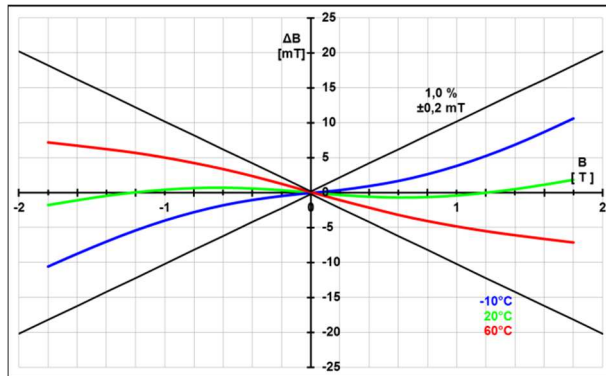

AS-NTP-Hot-05

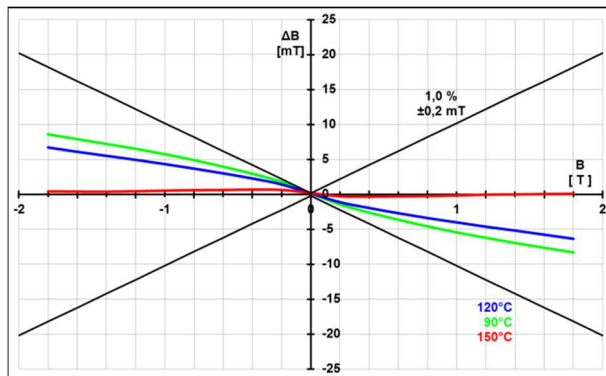

Axial Probe 12 T (AS-HAP)

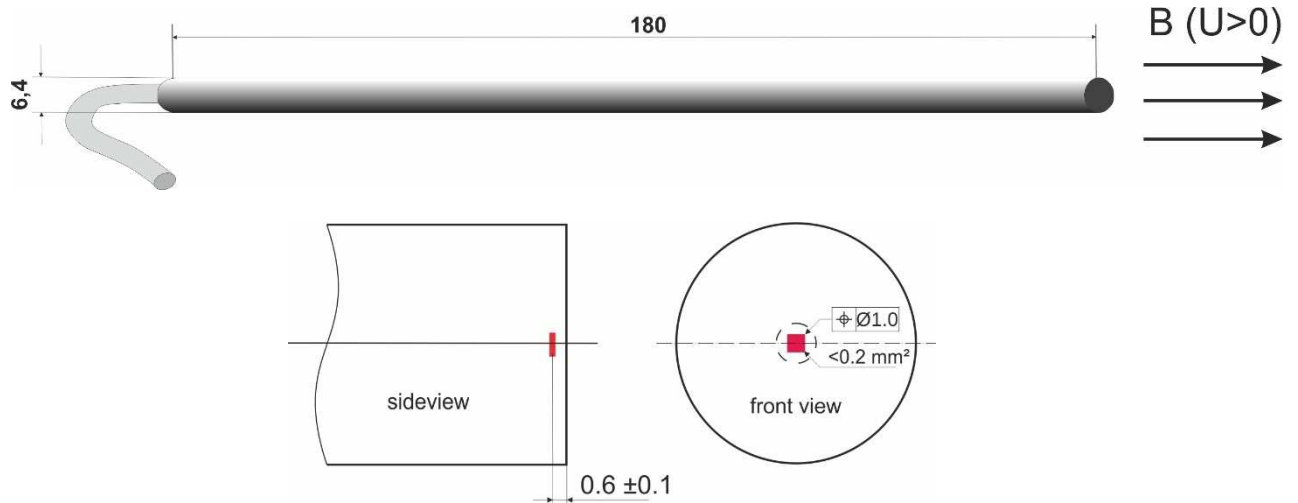

Ranges (with FM 302)	$\pm 0.2 \text{ T}$; $\pm 2 \text{ T}$; $\pm 20 \text{ T}$ (calibrated up to $\pm 12 \text{ T}$)
Stem size (L x \varnothing)	180 mm x 6.4 mm CFRP
Effective area	0.2 mm^2
Transfer factor	0.1 V/T
Bandwidth (-3 dB)	0 – 35 kHz
Rise time	$<3 \mu\text{s}$
Linearity error	$<2.0 \%$ $\pm 20 \text{ mT}$ (at $20 \text{ }^\circ\text{C}$)
Temperature coefficient	max. -0.1% /K, typ. -0.05% /K (0 to $50 \text{ }^\circ\text{C}$)
Zero drift	max. $\pm 0.05 \text{ mT/K}$, typ. $\pm 0.03 \text{ mT/K}$ (DC)
Noise	typ. $173 \mu\text{T}_{\text{RMS}}$ (10 Hz – 10 kHz) typ. $43 \mu\text{T}_{\text{PP}}$ (DC – 10 Hz, 50 s)
Operation temperature	$+5 \text{ }^\circ\text{C}$ to $+50 \text{ }^\circ\text{C}$
Storage temperature	$-10 \text{ }^\circ\text{C}$ to $+60 \text{ }^\circ\text{C}$
Max. relative humidity	70 % at $+35 \text{ }^\circ\text{C}$
Power	$\pm 3 \text{ V}$ through FM 302, AS-probe adapter, AS-Adapter 3 or PLC
Connector	15 pol. SubD
Output impedance	$<1 \Omega$
Length of cable	2.95 m

typ. test curve / linearity curve

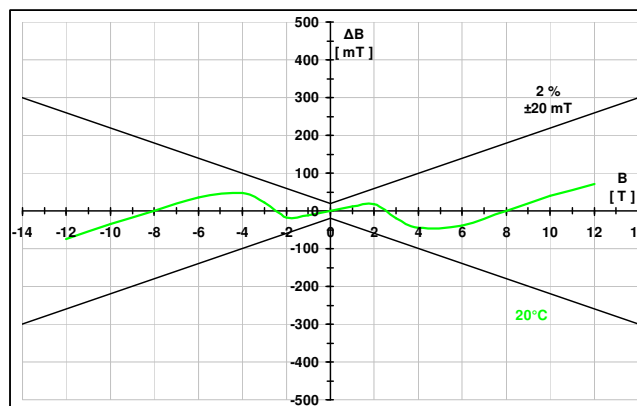

Transverse Probe 2000 mT (AS-NTP 0,6)

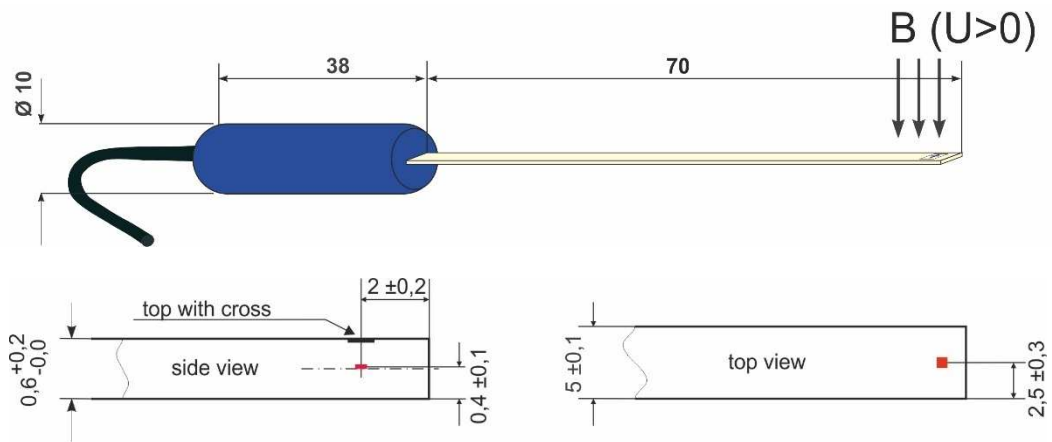

Ranges (with FM 302)	± 20 mT; ± 200 mT; ± 2000 mT
Stem size (L x W x T)	70 mm x 5 mm x 0,6 mm GFRP
Effective area	0.2 mm ²
Transfer factor	1 V/T
Bandwidth (- 3 dB)	0 - 35 kHz
Rise time	<3 μ s
Linearity error	<0.5 % ± 0.2 mT (at 20 °C ± 1 °C)
Temperature coefficient	max. -0.05 %/K, typ. -0.03 %/K (0 to 50 °C)
Zero drift	max. ± 0.020 mT/K, typ. ± 0.010 mT/K (DC)
Noise	typ. 21 μ T _{RMS} (10 Hz – 10 kHz) typ. 18 μ T _{PP} (DC – 10 Hz, 50 s)
Operation temperature	+5 °C to +100 °C (only at first 70 mm) +5 °C to +50 °C (grip, cable, probe connector)
Storage temperature	-10 °C to +60 °C
Max. relative humidity	70 % at +35 °C
Power	± 3 V through FM 302, AS-probe adapter, AS-Adapter 3 or PLC
Connector	15 pol. SubD
Output impedance	<1 Ω
Length of cable	1.5 m

typ. test curve / linearity curve

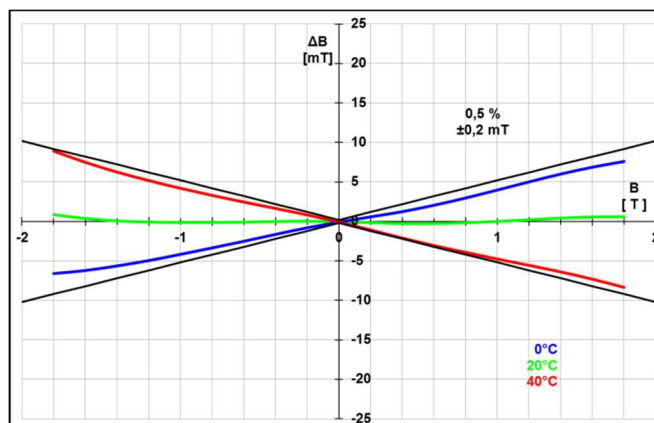

Transverse Probe Brass 2000 mT (AS-NTM)

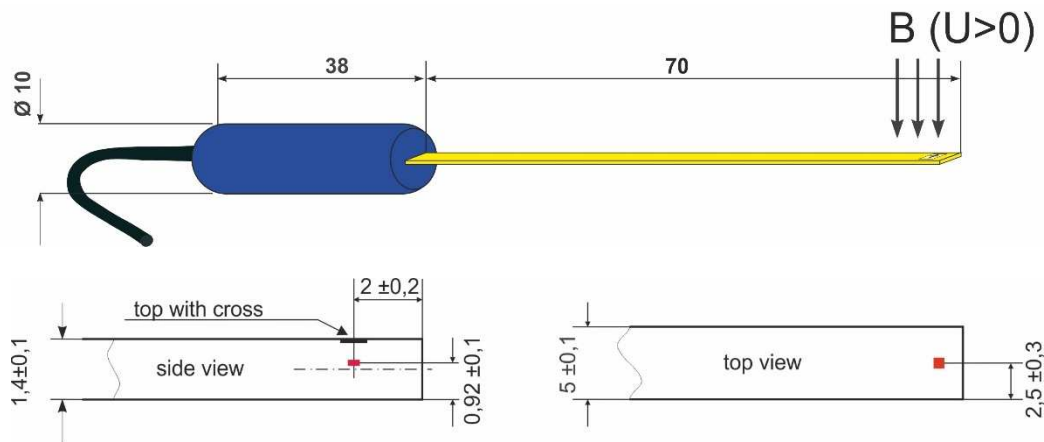

Ranges (with FM 302)	± 20 mT; ± 200 mT; ± 2000 mT
Stem size (L x W x T)	70 mm x 5 mm x 1,4 mm Brass
Effective area	0.2 mm ²
Transfer factor	1 V/T
Bandwidth (-3 dB)	0 - 25 kHz
Rise time	<6 μ s
Linearity error	<0.2 % ± 0.2 mT (at 20 °C ± 1 °C)
Temperature coefficient	max. -0.05 %/K, typ. -0.03 %/K (0 to 50 °C)
Zero drift	max. ± 0.020 mT/K, typ. ± 0.010 mT/K (DC)
Noise	typ. 21 μ T _{RMS} (10 Hz – 10 kHz) typ. 18 μ T _{PP} (DC – 10 Hz, 50 s)
Operation temperature	+5 °C to +50 °C
Storage temperature	-10 °C to +60 °C
Max. relative humidity	70 % at +35 °C
Power	± 3 V through FM 302, AS-probe adapter, AS-Adapter 3 or PLC
Connector	15 pol. SubD
Output impedance	<1 Ω
Length of cable	1.5 m

typ. test curve / linearity curve

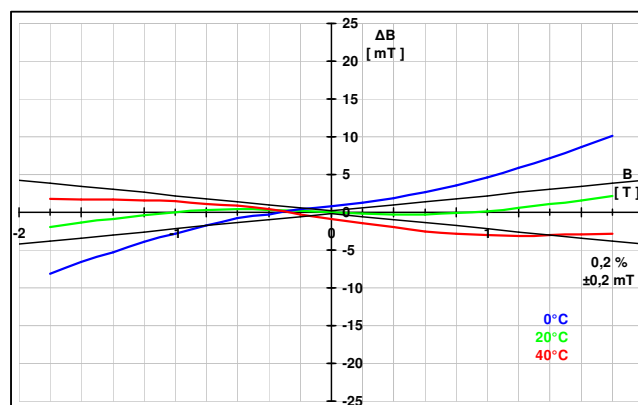

Transverse Probe Brass with Very High Precision 2000 mT (AS-NTM-2)

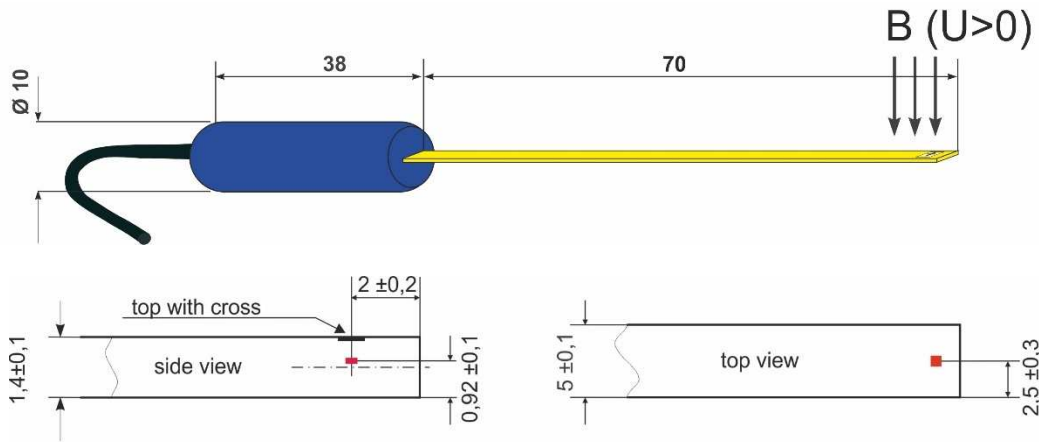

Ranges (with FM 302)	±20 mT; ±200 mT; ±2000 mT
Stem size (L x W x T)	70 mm x 5 mm x 1,4 mm Brass
Effective area	0.12 mm ²
Transfer factor	1 V/T
Bandwidth (- 3 dB)	0 – 25 kHz
Rise time	<6 µs
Linearity error	<0.05 % ±0.2 mT (DC, at 20 °C ±1 °C)
Temperature coefficient	max. ±0.005 %/K (5 °C to 50 °C)
Zero drift	max. ±0.005 mT/K, typ. ±0.003 mT/K
Noise	typ. 21 µT _{RMS} (10 Hz – 10 kHz) typ. 12 µT _{PP} (DC – 10 Hz, 50 s)
Operation temperature	+5 °C to +50 °C
Storage temperature	-10 °C to +60 °C
Max. relative humidity	70 % at +35 °C
Power	±3 V through FM 302, AS-probe adapter, AS-Adapter 3 or PLC
Connector	15 pol. SubD
Output impedance	<1 Ω
Length of cable	1.5 m

typ. test curve / linearity curve

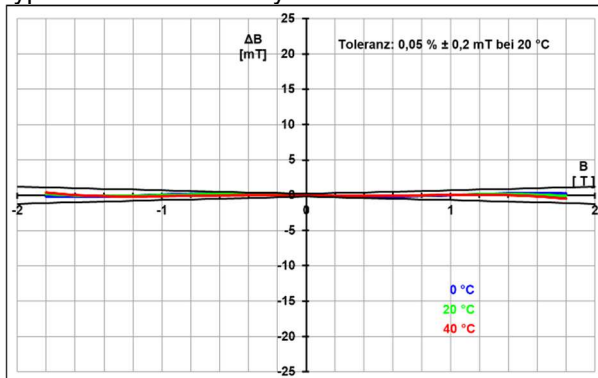

x10 magnified

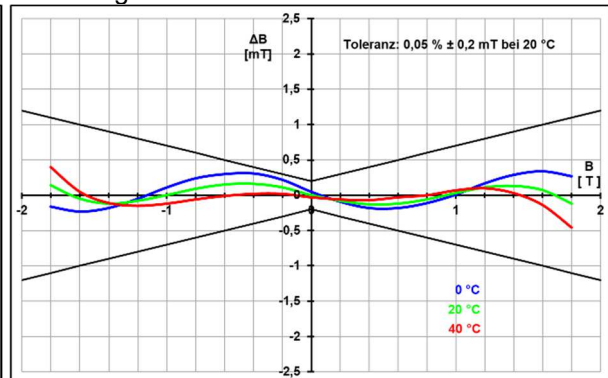

Axial Probe 2000 mT (AS-NAP)

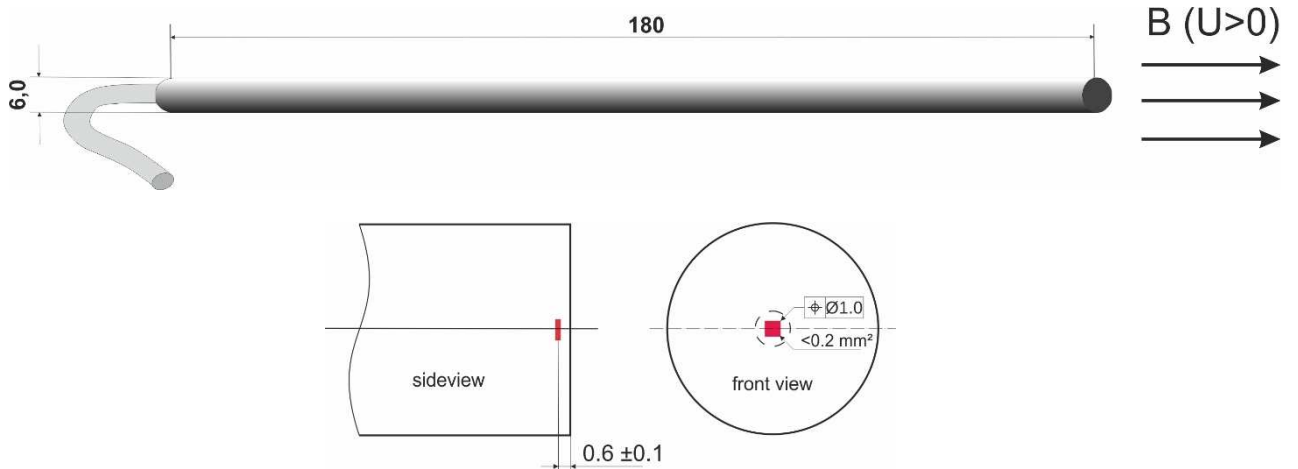

Ranges (with FM 302)	$\pm 20 \text{ mT}$; $\pm 200 \text{ mT}$; $\pm 2000 \text{ mT}$
Stem size (L x \varnothing)	180 mm x 6.0 mm CFRP
Effective area	0.2 mm^2
Transfer factor	1 V/T
Bandwidth (- 3 dB)	0 - 35 kHz
Rise time	$< 3 \mu\text{s}$
Linearity error	$< 0.5 \% \pm 0.2 \text{ mT}$ (at $20 \text{ }^\circ\text{C} \pm 1 \text{ }^\circ\text{C}$)
Temperature coefficient	max. $-0.05 \%/\text{K}$, typ. $-0.03 \%/\text{K}$ (0 to $50 \text{ }^\circ\text{C}$)
Zero drift	max. $\pm 0.020 \text{ mT}/\text{K}$, typ. $\pm 0.010 \text{ mT}/\text{K}$ (DC)
Noise	typ. $21 \mu\text{T}_{\text{RMS}}$ (10 Hz – 10 kHz) typ. $18 \mu\text{T}_{\text{PP}}$ (DC – 10 Hz, 50 s)
Operation temperature	$+5 \text{ }^\circ\text{C}$ to $+50 \text{ }^\circ\text{C}$
Storage temperature	$-10 \text{ }^\circ\text{C}$ to $+60 \text{ }^\circ\text{C}$
Max. relative humidity	70 % at $+35 \text{ }^\circ\text{C}$
Power	$\pm 3 \text{ V}$ through FM 302, AS-probe adapter, AS-Adapter 3 or PLC
Connector	15 pol. SubD
Output impedance	$< 1 \Omega$
Length of cable	1.5 m

typ. test curve / linearity curve

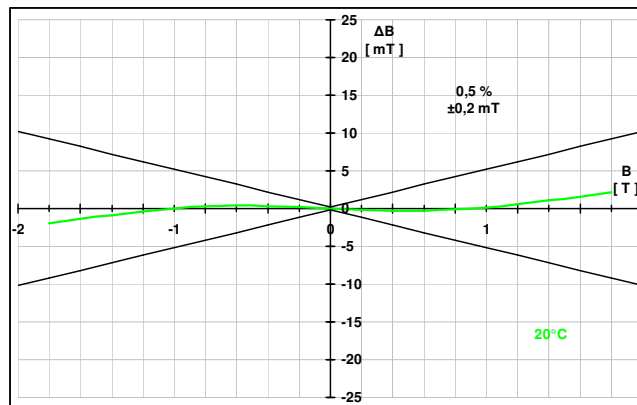

Transverse Probe Hot with Improved Temperature Characteristics 2000 mT (AS-NTP-Hot-05)

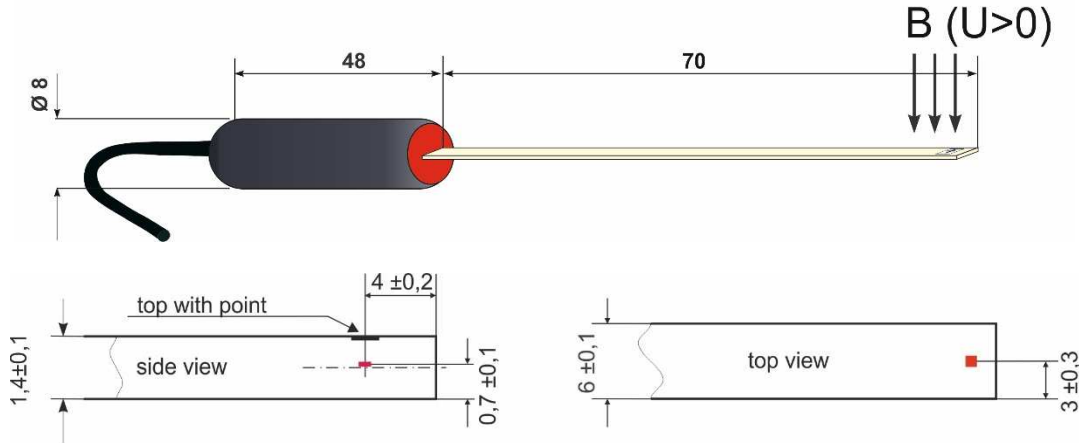

Ranges (with FM 302)	± 20 mT; ± 200 mT; ± 2000 mT
Stem size (L x W x T)	70 mm x 6 mm x 1,4 mm GFRP
Effective area	0.5 mm ²
Transfer factor	1 V/T
Bandwidth (- 3 dB)	0 - 35 kHz
Rise time	<3 μ s
Linearity error	<0.2 % ± 0.2 mT (at 20 °C ± 1 °C)
Temperature error	< ± 1.0 % ± 0.2 mT (-10 °C to +150 °C)
Noise	typ. 21 μ T _{RMS} (10 Hz – 10 kHz) typ. 18 μ T _{PP} (DC – 10 Hz, 50 s)
Operation temperature	-40 °C to +150 °C (<u>only</u> probe, grip and cable) +5 °C to +50 °C (probe connector)
Storage temperature	-10 °C to +60 °C
Max. relative humidity	70 % at +35 °C
Power	± 3 V through FM 302, AS-probe adapter, AS-Adapter 3 or PLC
Connector	15 pol. SubD
Output impedance	<1 Ω
Length of cable	2.95 m

typ. test curve / linearity curves

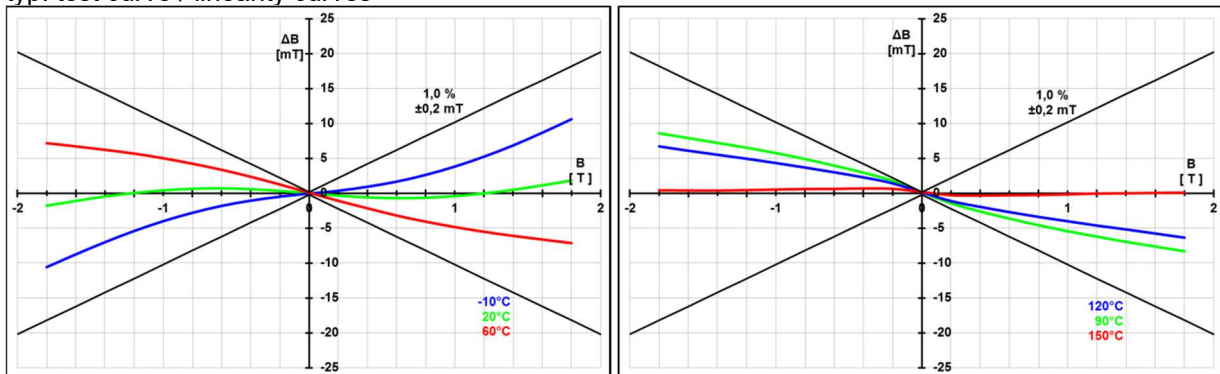

Transverse Probe Flex 2000 mT (AS-NTP-Flex)

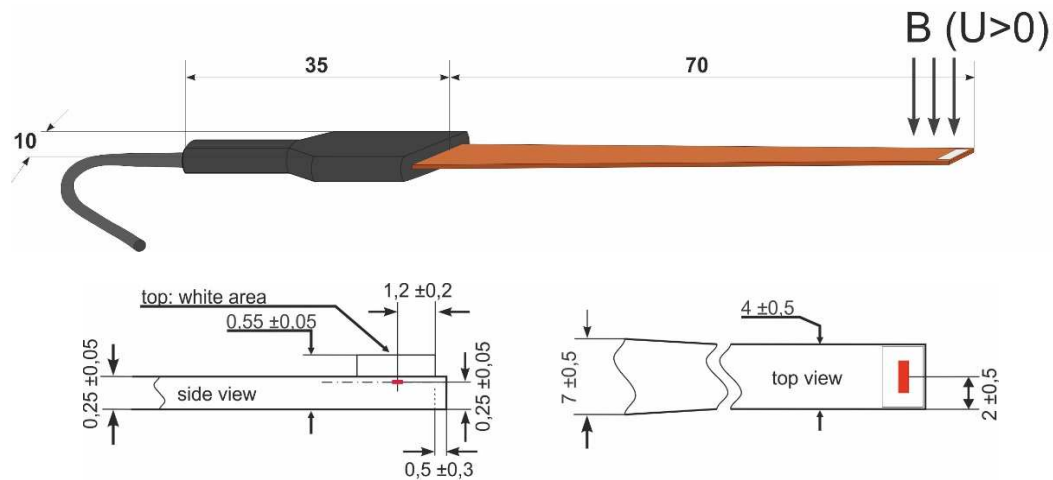

Ranges (with FM 302)	±20 mT; ±200 mT; ±2000 mT
Stem size (L x W x T)	70 mm x 4 mm x 0,55 mm (on the top) Kapton
Effective area	2 mm ²
Transfer factor	1 V/T
Bandwidth (-3 dB)	0 - 0.5 kHz
Rise time	<0.2 ms
Linearity error	<0.5 % ±0.2 mT (0 to ±1.5 T, at 20 °C ±1 °C)
Temperature coefficient	max. -0.05 %/K, typ. -0.03 %/K (0 to 50 °C)
Zero drift	max. ±0.020 mT/K, typ. ±0.010 mT/K (DC)
Noise	typ. 7,5 μT _{RMS} (10 Hz – 1 kHz) typ. 13 μT _{PP} (DC – 10 Hz, 50 s)
Operation temperature	+5 °C to +100 °C (only at first 70 mm)
Storage temperature	+5 °C to +50 °C (grip, cable, probe connector)
max. relative humidity	-10 °C to +60 °C 70 % at +35 °C
Power	±3 V through FM 302, AS-probe adapter, AS-Adapter 3 or PLC
Connector	15 pol. SubD
Output impedance	<1 Ω
Length of cable	1.5 m

typ. test curve / linearity curve

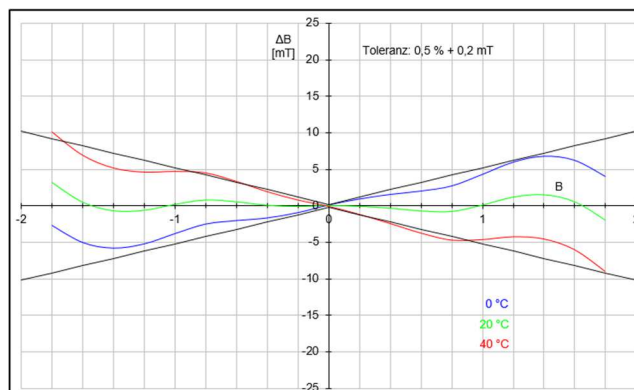

Transverse Probe Flex 2000 mT (AS-NTP-Flex 0,6)

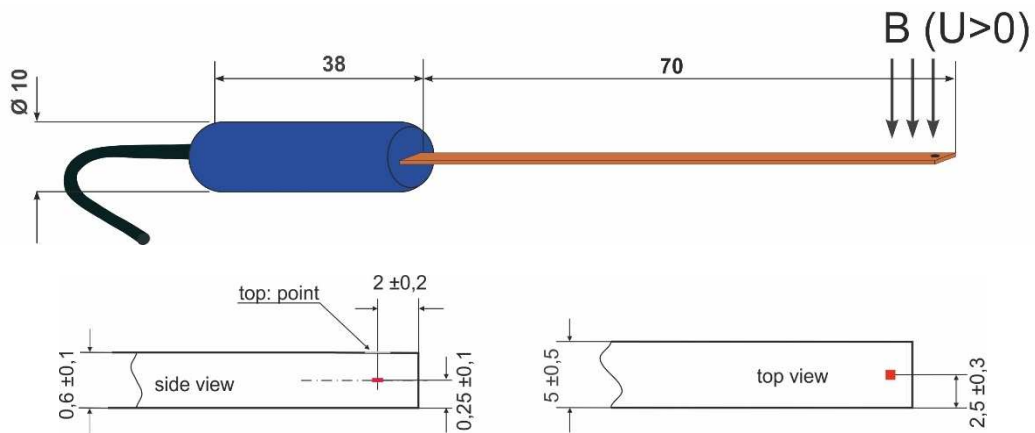

Ranges (with FM 302)	±20 mT; ±200 mT; ±2000 mT
Stem size (L x W x T)	70 mm x 5 mm x 0,6 ±0,1 mm Kapton
Effective area	0.2 mm ²
Transfer factor	1 V/T
Bandwidth (- 3 dB)	0 - 35 kHz
Rise time	<3 μs
Linearity error	<0.5 % ±0.2 mT (at 20 °C ±1 °C)
Temperature coefficient	max. -0.05 %/K, typ. -0.03 %/K (0 to 50 °C)
Zero drift	max. ±0.020 mT/K, typ. ±0.010 mT/K (DC)
Noise	typ. 21 μT _{RMS} (10 Hz – 10 kHz) typ. 18 μT _{PP} (DC – 10 Hz, 50 s)
Operation temperature	+5 °C to +150 °C (<u>only</u> at first 70 mm)
Storage temperature	+5 °C to +50 °C (grip, cable, probe connector)
max. relative humidity	-10 °C to +60 °C 70 % at +35 °C
Power	±3 V through FM 302, AS-probe adapter, AS-Adapter 3 or PLC
Connector	15 pol. SubD
Output impedance	<1 Ω
Length of cable	1.5 m

typ. test curve / linearity curve

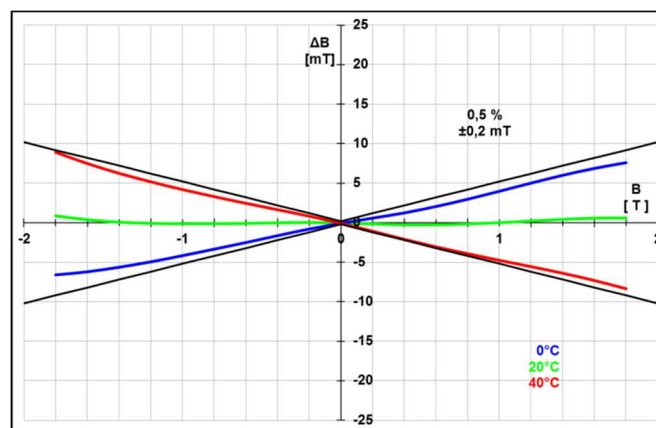

Transverse Probe Wire 2000 mT (AS-NCu-Wire)



Ranges (with FM 302)	± 20 mT; ± 200 mT; ± 2000 mT
Sensor thickness / guide	0,6 \pm 0,1 mm x approximately 150 mm
Effective area	2 mm x 1 mm
Transfer factor	1 V/T
Bandwidth (-3 dB)	0 – 35 kHz
Rise time	<3 μ s
Linearity error	<0.5 % \pm 0,2 mT (0 to ± 1.5 T, at 20 $^{\circ}$ C ± 1 $^{\circ}$ C)
Temperature coefficient	max. -0.05 %/K, typ. -0.03 %/K (0 to 50 $^{\circ}$ C)
Zero drift	max. ± 0.020 mT/K, typ. ± 0.010 mT/K (DC)
Noise	typ. 25 μ T _{RMS} (10 Hz – 10 kHz) typ. 15 μ T _{PP} (DC – 10 Hz, 50 s)
Operation temperature	+5 $^{\circ}$ C to +100 $^{\circ}$ C (<u>only</u> at first 150 mm)
Storage temperature	+5 $^{\circ}$ C to +50 $^{\circ}$ C (grip, cable, probe connector)
Max. relative humidity	-10 $^{\circ}$ C to +60 $^{\circ}$ C 70 % at +35 $^{\circ}$ C
Power	± 3 V through FM 302, AS-probe adapter, AS-Adapter 3 or PLC
Connector	15 pol. SubD
Output impedance	<1 Ω
Length of cable	1.5 m

typ. test curve / linearity curve

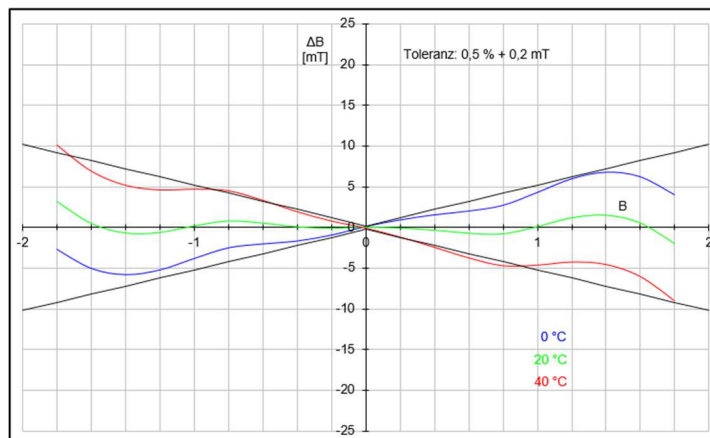

Transverse Probe Brass 200 mT (AS-LTM)

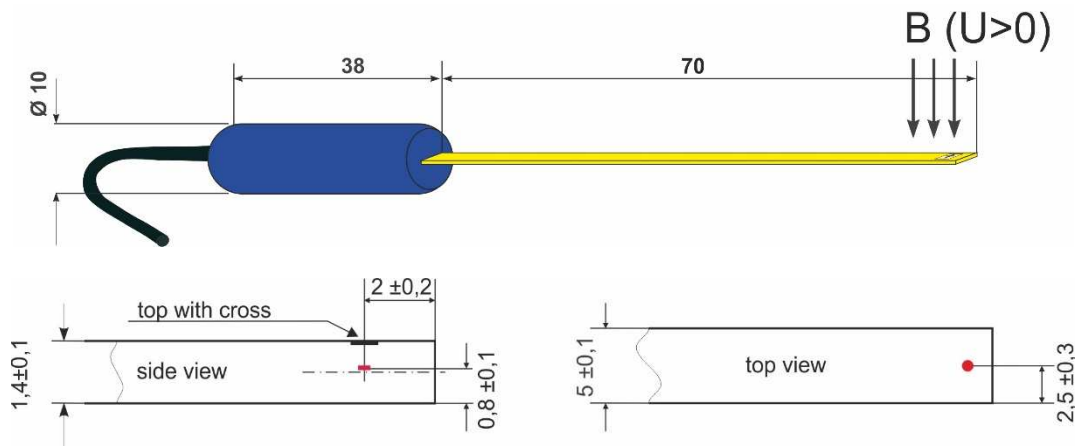

Ranges (with FM 302)	± 2 mT; ± 20 mT; ± 200 mT
Stem size (L x W x T)	70 mm x 5 mm x 1,4 \pm 0,1 mm Brass
Effective area	0.2 mm ²
Transfer factor	10 V/T
Bandwidth (-3 dB)	0 to 10 kHz
Rise time	<30 μ s
Linearity error	<0.2 % \pm 0.1 mT (at 25 $^{\circ}$ C \pm 1 $^{\circ}$ C)
Temperature coefficient	max. -0.05 %/K, typ. -0.03 %/K (0 to 50 $^{\circ}$ C)
Zero drift	max. \pm 0.010 mT/K, typ. \pm 0.005 mT/K (DC)
Noise	typ. 14 μ T _{RMS} (10 Hz – 10 kHz) typ. 34 μ T _{PP} (DC – 10 Hz, 50 s)
Operation temperature	+5 $^{\circ}$ C to +50 $^{\circ}$ C
Storage temperature	-10 $^{\circ}$ C to +60 $^{\circ}$ C
max. relative humidity	70 % at +35 $^{\circ}$ C
Power	± 3 V through FM 302, AS-probe adapter, AS-Adapter 3 or PLC
Connector	15 pol. SubD
Output impedance	<1 Ω
Length of cable	1.5 m

typ. test curve / linearity curve

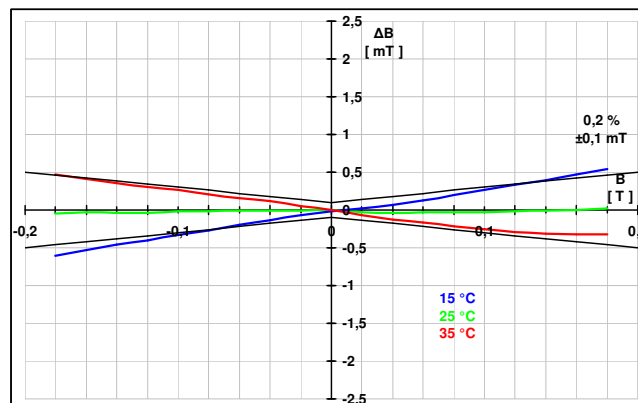

Axial Probe 200 mT (AS-LAP)

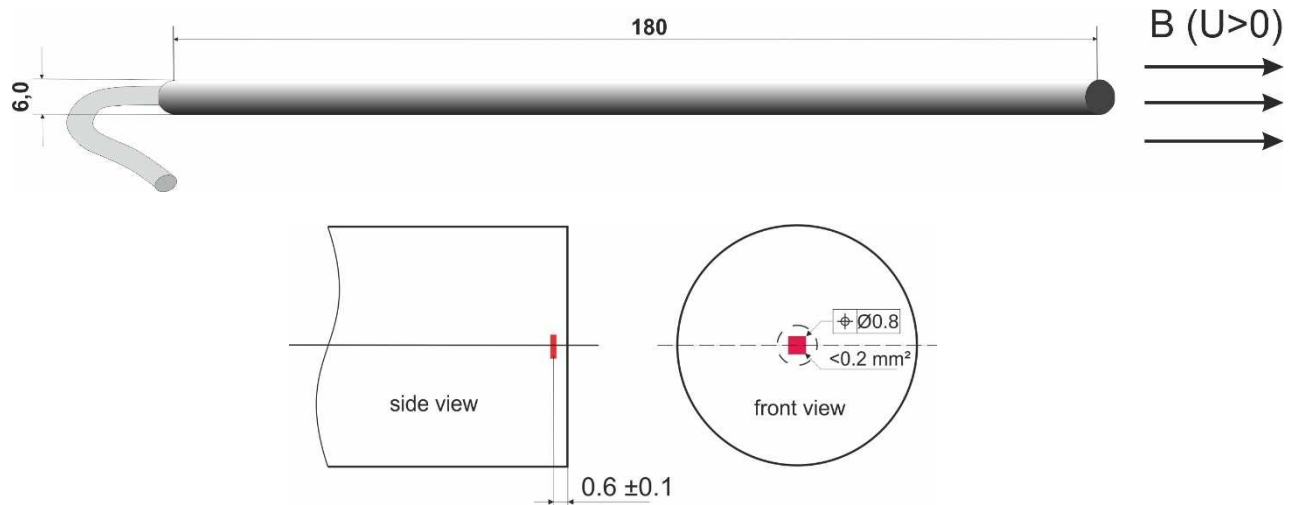

Ranges (with FM 302)	$\pm 2 \text{ mT}$; $\pm 20 \text{ mT}$; $\pm 200 \text{ mT}$
Stem size (L x \varnothing)	180 mm x 6.0 mm CFRP
Effective area	0.2 mm^2
Transfer factor	10 V/T
Bandwidth (-3 dB)	0 – 10 kHz
Rise time	$<30 \mu\text{s}$
Linearity error	$<0.5 \% \pm 0.1 \text{ mT}$ (at $25 \text{ }^\circ\text{C} \pm 1 \text{ }^\circ\text{C}$)
Temperature coefficient	max. $-0.05 \%/\text{K}$, typ. $-0.03 \%/\text{K}$ (0 to $50 \text{ }^\circ\text{C}$)
Zero drift	max. $\pm 0.010 \text{ mT}/\text{K}$, typ. $\pm 0.005 \text{ mT}/\text{K}$ (DC)
Noise	typ. $14 \mu\text{T}_{\text{RMS}}$ (10 Hz – 10 kHz) typ. $34 \mu\text{T}_{\text{PP}}$ (DC – 10 Hz, 50 s)
Operation temperature	$+5 \text{ }^\circ\text{C}$ to $+50 \text{ }^\circ\text{C}$
Storage temperature	$-10 \text{ }^\circ\text{C}$ to $+60 \text{ }^\circ\text{C}$
Max. relative humidity	70 % at $+35 \text{ }^\circ\text{C}$
Power	$\pm 3 \text{ V}$ through FM 302, AS-probe adapter, AS-Adapter 3 or PLC
Connector	15 pol. SubD
Output impedance	$<1 \Omega$
Length of cable	1.5 m

typ. test curve / linearity curve

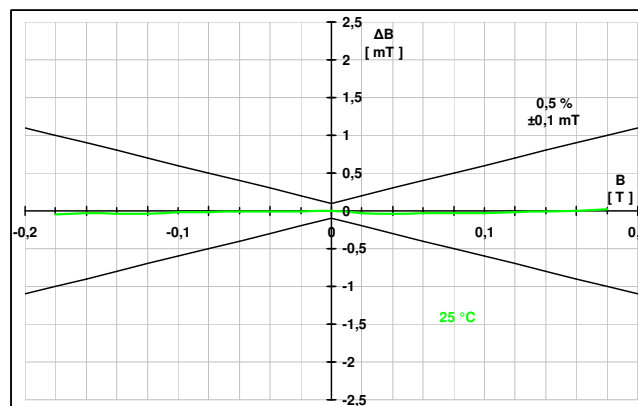

Transverse Probe 20 mT (AS-VTP)

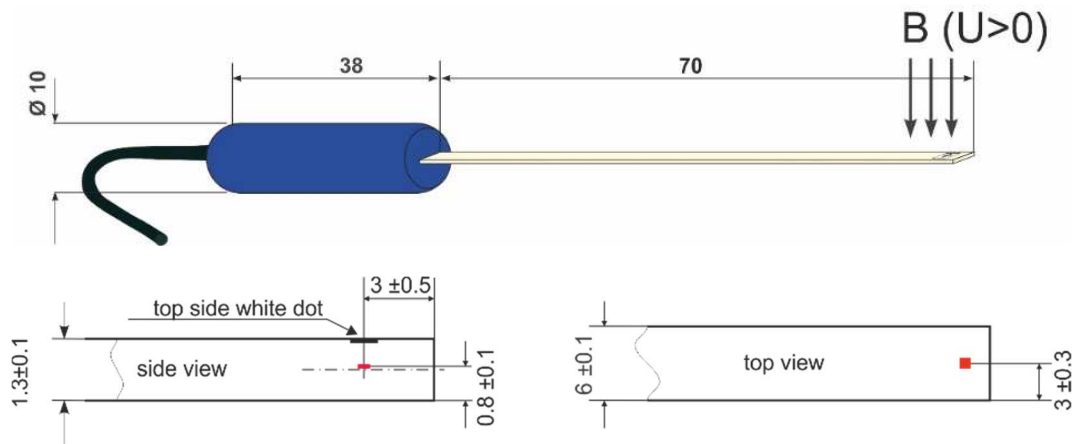

Range (with FM 302)	±200 μ T; ±2 mT; ±20 mT
Stem size (L x W x T)	70 mm x 6 mm x 1.3 ± 0.1 mm GFRP
Effective area	0.02 mm ²
Transfer factor	1 V / 10 mT
Bandwidth (-3 dB)	0 - 1 kHz
Rise time	<300 μ s
Linearity error	<0.5 % ±10 μ T (at 23 °C ±1 °C)
Temperature coefficient	max. ±0.06 %/K, typ. ±0.03 %/K (0 to 50 °C)
Zero drift	max. ±2 μ T/K (DC)
Noise	typ. 5 μ T _{RMS} (10 Hz – 1 kHz) typ. 2 μ T _{PP} (DC – 10 Hz, 50 s)
Operation temperature	+5 °C to +50 °C
Storage temperature	-10 °C to +60 °C
Max. relative humidity	70 % at +35 °C
Power	±3 V through FM 302, AS-probe adapter, AS-Adapter 3 or PLC
Connector	15 pol. SubD
Output impedance	<1 Ω
Length of cable	1.5 m

typ. test curve / linearity curve

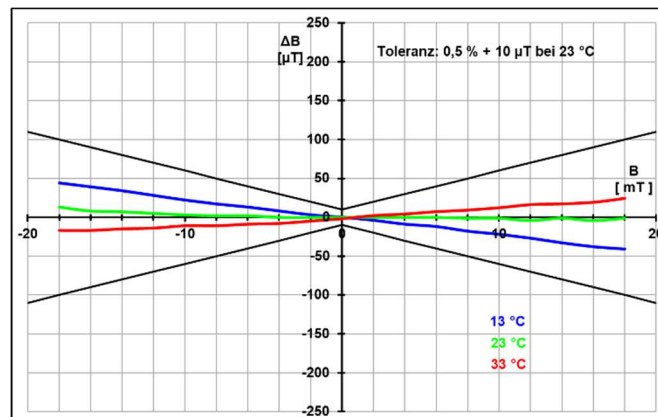

GEO-X Axial Probe 200 μ T (AS-UAP GEO-X)

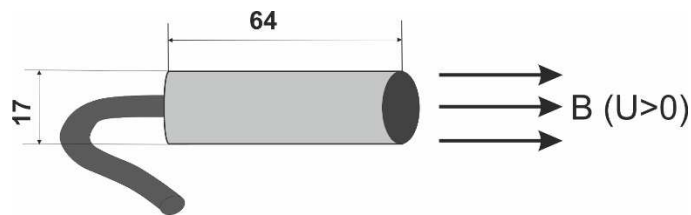

Ranges (with FM 302)	$\pm 2 \mu\text{T}$; $\pm 20 \mu\text{T}$; $\pm 200 \mu\text{T}$
Case size (L x \varnothing)	64 mm x 17 mm
Effective volume	$\varnothing 5 \text{ mm} \times 22 \text{ mm}$
Transfer factor	1 V / 100 μT
Bandwidth (-3 dB)	0 – 800 Hz (2 μT - / 20 μT -range) 0 – 500 Hz (200 μT -range)
Rise time	<0.3 ms
Linearity error	<0.8 % $\pm 0.2 \mu\text{T}$ (at 25 °C)
Temperature coefficient	max. $\pm 0.1 \text{ \%}/\text{K}$ (10 °C to 50 °C)
Zero drift	max. $\pm 10 \text{ nT}/\text{K}$
Hysteresis	max. 0.1 % of value
magnetic flux density	max. $\pm 200 \mu\text{T}$ or 140 μT_{eff}
Noise	typ. 4,5 nT _{RMS} (10 Hz – 1 kHz) typ. 6 nT _{PP} (DC – 10 Hz, 50 s)
Operation temperature	+5 °C to +50 °C
Storage temperature	-10 °C to +60 °C
Max. relative humidity	70 % at +35 °C
Power	$\pm 3 \text{ V}$ through FM 302, AS-probe adapter, AS-Adapter 3 or PLC
Connector	15 pol. SubD
Output impedance	<1 Ω
Length of cable	1.5 m

typ. test curve / linearity curve

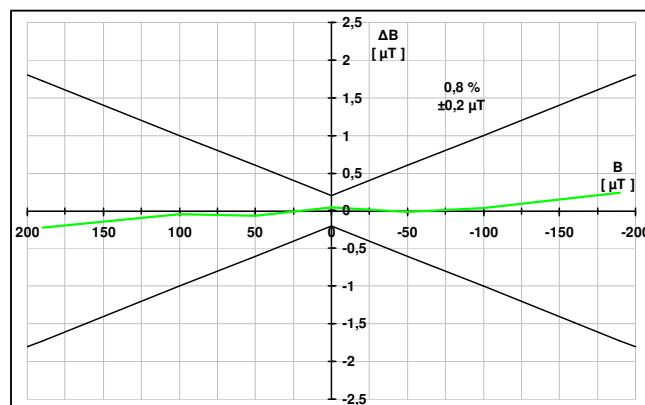

Lot Axial Probe 200 μ T (AS-UAP Lot)

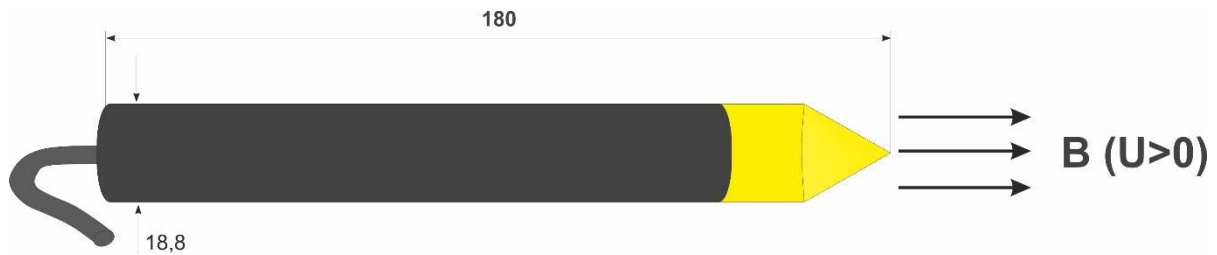

Ranges (with FM 302)	$\pm 2 \mu\text{T}$; $\pm 20 \mu\text{T}$; $\pm 200 \mu\text{T}$
Case size (L x \varnothing)	150 mm x \varnothing 18,8 mm Brass
Effective volume	\varnothing 5 mm x 22 mm
Transfer factor	1 V / 100 μT
Bandwidth (-3 dB)	0 – 800 Hz (2 μT - / 20 μT -range) 0 – 500 Hz (200 μT -range)
Rise time	<0.3 ms
Linearity error	<0.8 % $\pm 0.2 \mu\text{T}$ (at 25 °C)
Temperature coefficient	max. $\pm 0.1 \%$ /K (10 °C to 50 °C)
Zero drift	max. $\pm 10 \text{ nT/K}$
Hysteresis	max. 0.1 % of value
magnetic flux density	max. $\pm 200 \mu\text{T}$ or 140 μT_{eff}
Noise	typ. 4,5 nT_{RMS} (10 Hz – 1 kHz) typ. 6 nT_{PP} (DC – 10 Hz, 50 s)
Operation temperature	+5 °C to +50 °C
Storage temperature	-10 °C to +60 °C
Max. relative humidity	70 % at +35 °C
Power	$\pm 3 \text{ V}$ through FM 302, AS-probe adapter, AS-Adapter 3 or PLC
Connector	15 pol. SubD
Output impedance	<1 Ω
Length of cable	1.5 m

typ. test curve / linearity curve

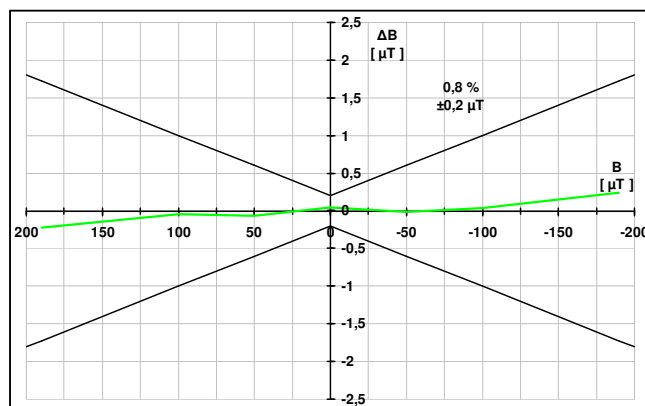

Usage of the AS-active-probes with the Teslameter FM 302:

Usually the AS-active-probe is simply connected to the Teslameter. The Measurement can be started immediately.

Also all extended possibilities of the Teslameter FM 302 like calibrated analog output, control via USB interface or power supply with power adapter are usable in that way.

Further details can be found in the data sheet of the Teslameter FM 302.

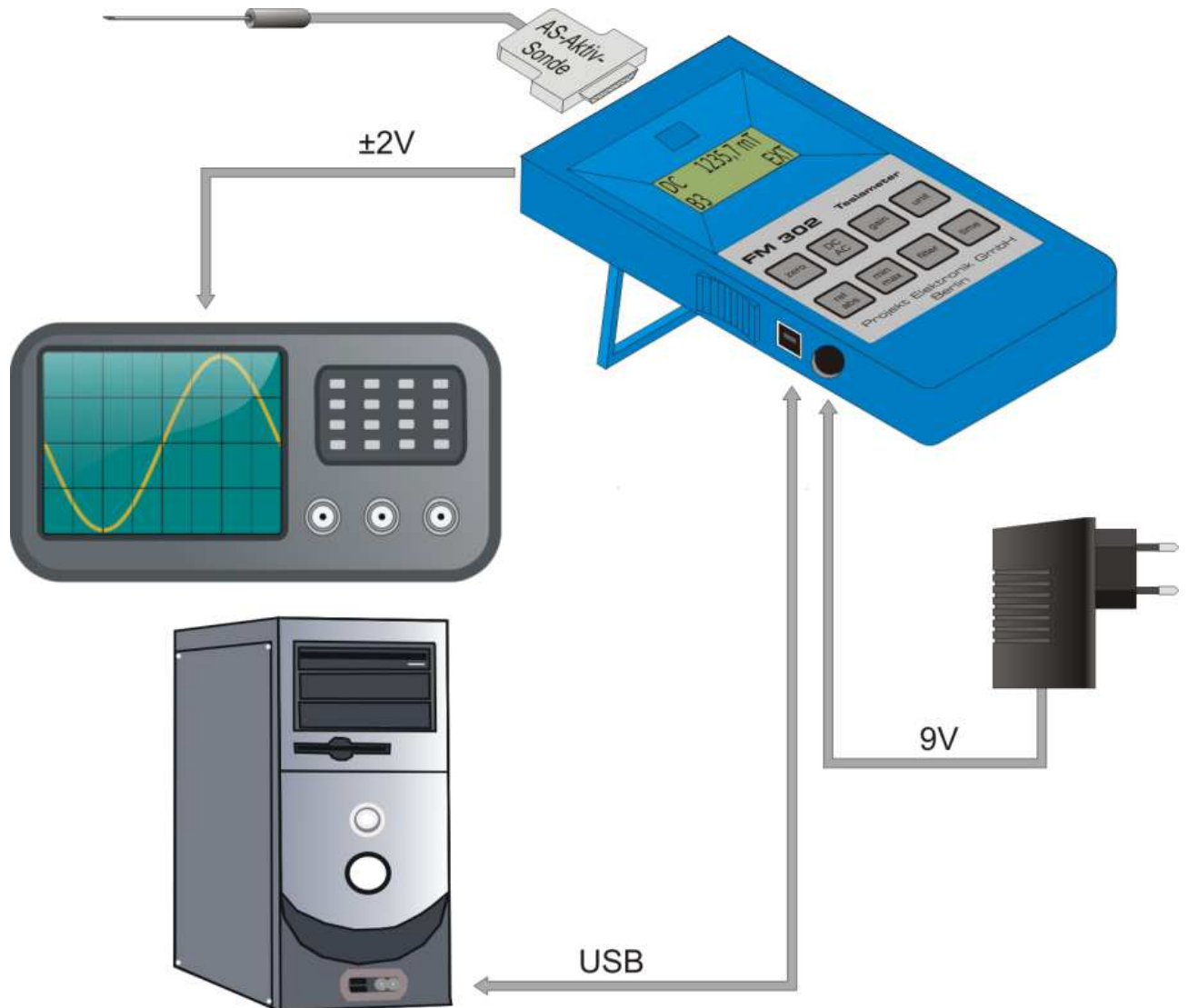

Usage of the AS-active-probes with the AS-probe adapter:

The AS-probe adapter amplifies the analog output signal of the probes to $\pm 10\text{ V}$ which is the typical input range of analog inputs of a PLC.

To be usable all-purpose the AS-probe adapter has a wide supply voltage range from 9 V to 36 V and provides high-stable $\pm 3\text{ V}$ necessary to supply the AS-active-probes. Additionally the measurement signal is galvanically isolated from the power supply.

Further details can be found in the data sheet of the AS-probe adapter.

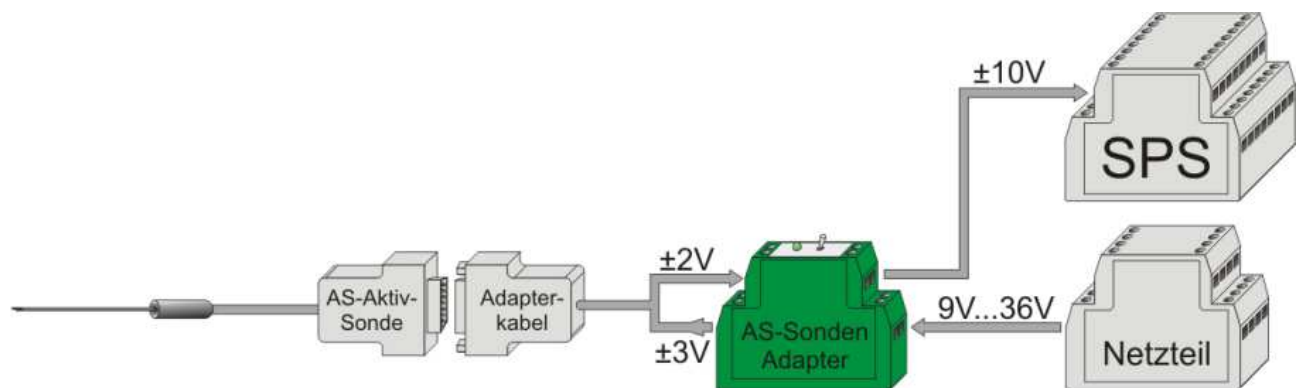

Usage of the AS-active-probes as autonomous transducer:

Our AS-active-probes also can be operated autonomously. Thereto merely they have to be powered externally with $\pm 3\text{ V}$ ($\pm 1\%$) at max. 20 mA . Then the analog output signal of the AS-probes can be applied to the gain programmable amplifier input of a PLC.

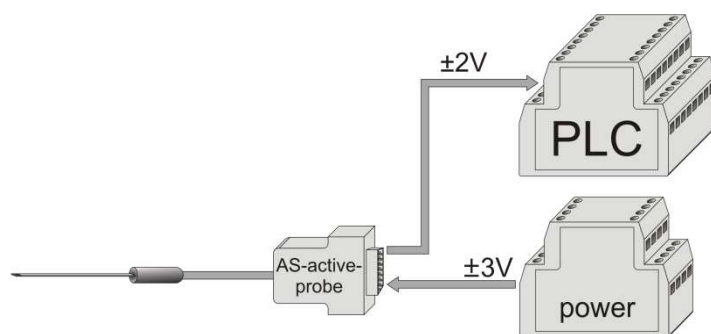

The pin configuration of the probe is shown in the graphic below. All other pins are reserved for future use or are only relevant in combination with the Teslometer FM 302. These pins have to remain unconnected.

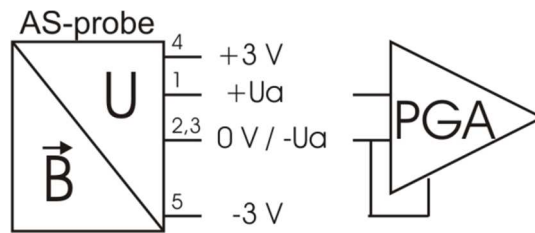

Like shown in the inner structure schematic the output signal at pin 1 is always referred to the ground signal at pin 2 and 3. This ground and the supply voltages +3 V (pin 4) and -3 V (pin 5) have to be provided from the outside.

The AS-active-probes may not be powered with asymmetric voltages.

It should be observed, that in the probe a connection between GND, plug shield, plug case and cable shield is made. At probes with brass tube, this is also connected to GND.

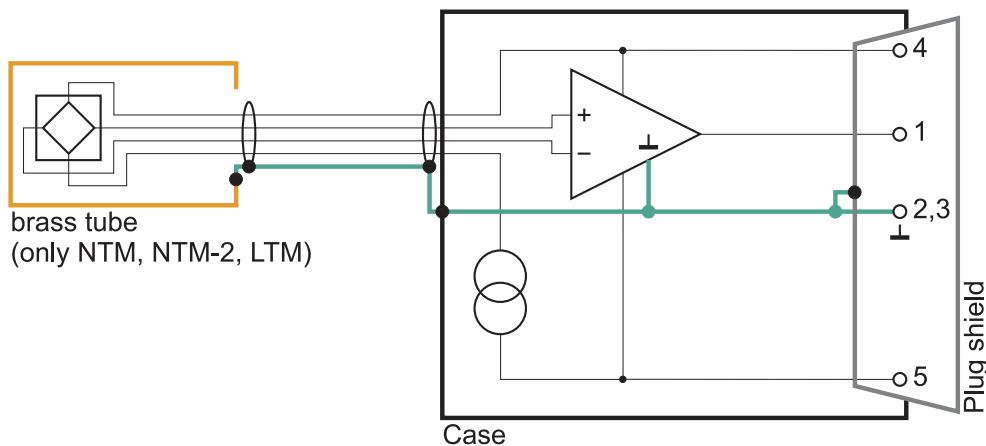

Usage of the AS-active-probes with the Interface AS-Adapter 3:

Up to three AS-active probes can be simultaneously operated with the AS-Adapter 3. The AS-Adapter 3 supplies the AS active probes with $\pm 3\text{ V}$ in a highly stable manner.

The signals from all 3 probes are available simultaneously and in parallel via the BNC connections or via the terminal contacts.

The probe signals are amplified with x5 or x50, so that with $\pm 2\text{ V}$ or $\pm 0.2\text{ V}$ they can output $\pm 10\text{ V}$ for a PLC system and Provide oscilloscope.

Further details can be found in the data sheet of the Interface AS-Adapter 3.

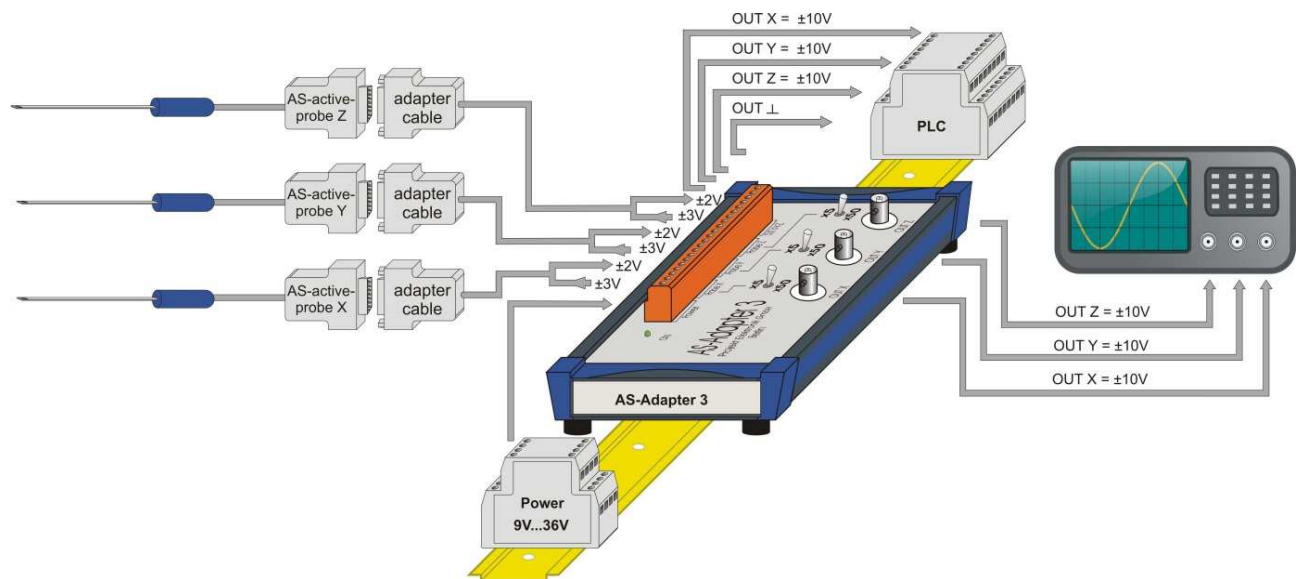

Figure 1 Connection AS-Adapter 3 with 1-axis AS-active probes

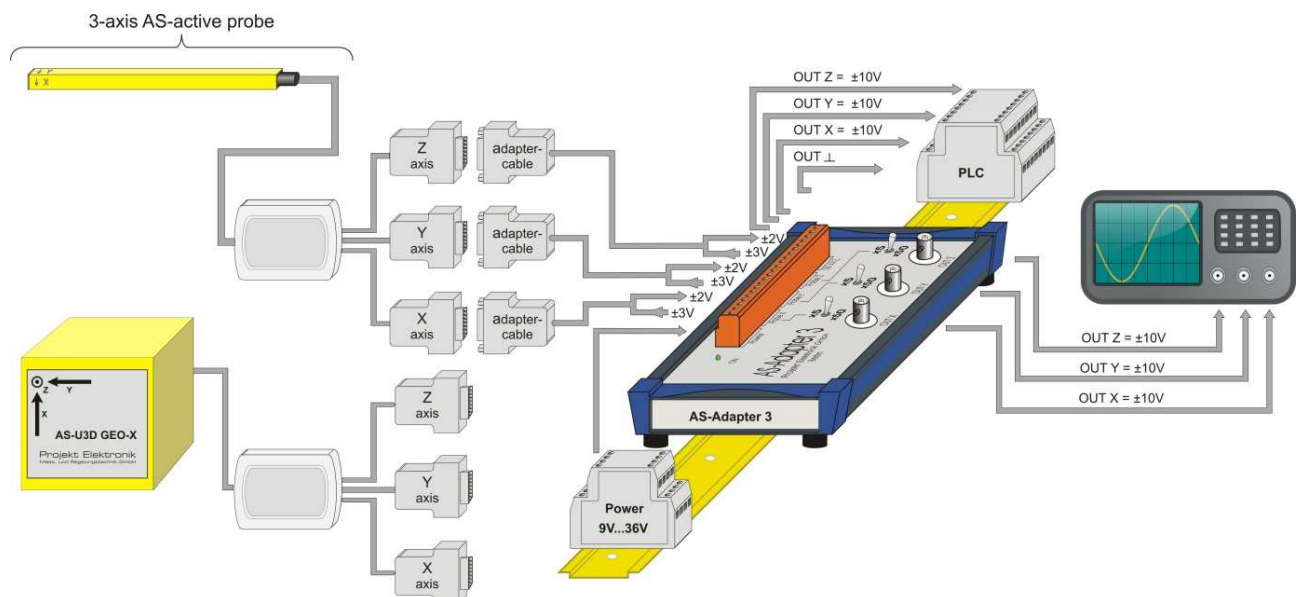

Figure 2 Connection AS-Adapter 3 with 3-axis AS-active probe