

AS-probe adapter for PLC

- for supply and autonomous operation of an AS-active-probe
- wide supply voltage range 9 V to 36 V
- amplification of the probe signal switchable x5 or x50
- galvanic isolation of supply voltage and measuring system
- standardized analog output with ± 10 V
- factory calibration certificate
- calibrated analog output: DC – 100 kHz
- Made in Germany

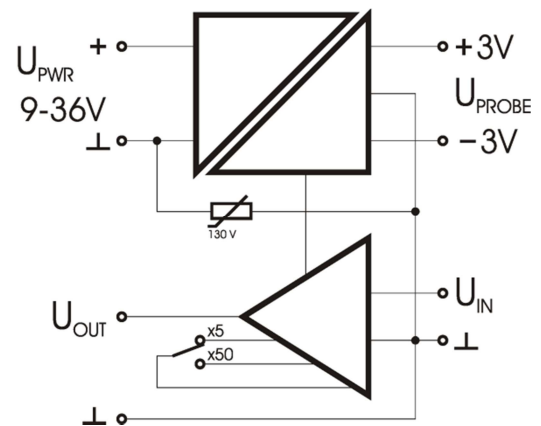
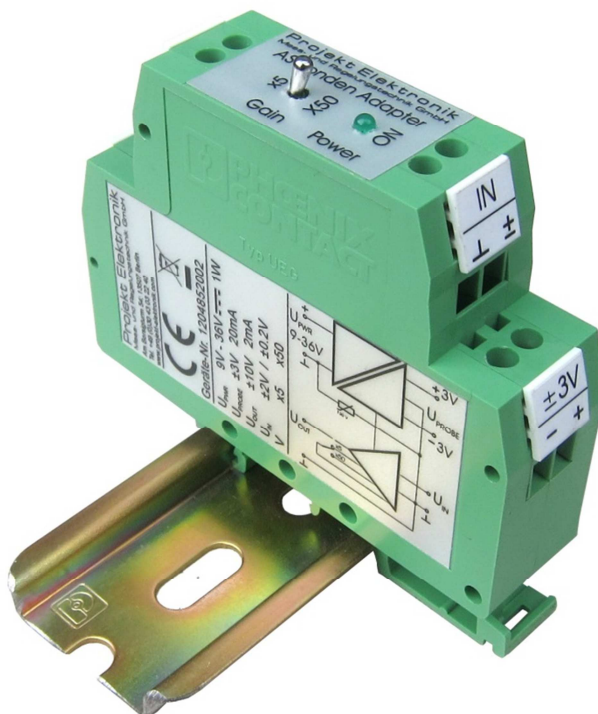

The AS-probe adapter is designed for autonomous operation of our AS-active probes without teslameter.

As a result of the wide supply voltage range of 9 V_{DC} to 36 V_{DC} the AS-probe adapter may be used universal in different system configurations. Furthermore the AS-probe adapter galvanically isolates the power supply from the probe supply and the measuring electronic.

The AS-probe adapter provides high stable ± 3 V necessary to supply the AS-active probes. To ease the connection of the AS-active probe to existing analog inputs with ± 10 V input range, the AS-probe adapter contains an integrated amplifier. This amplifies the output signal of the AS-active probes from ± 2 V to ± 10 V. With a switch, an additionally 10times higher gain can be chosen which allows to perform even sensitive measurements.

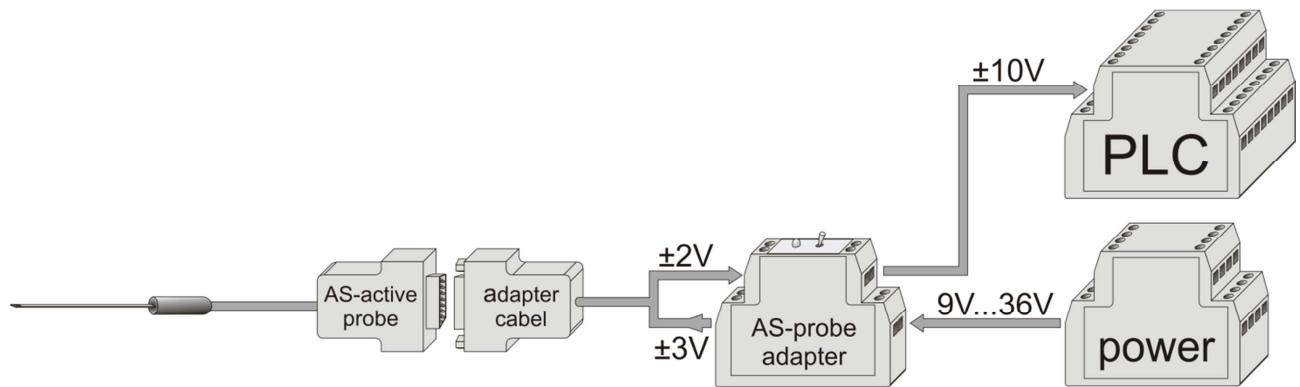

The analog output of the adapter is calibrated and thus can be used e.g. for displaying magnetic pulses in the μs -range (oscilloscope), recording of measurements and for field control. The bandwidth of the analog output reaches from DC to a least 100 kHz. Therefore it is suitable for measuring both constant magnetic fields and alternating magnetic fields. The actual usable bandwidth depends on used AS-active probe.

After connecting the desired probe, the measurement can start without adjusting zero and scale because all AS-active probes are calibrated. Hence replacement probes can be used at any time.

All of our AS-active probes may be connected to the AS-probe adapter. This allows the fast adaptation to different measuring task by simply plugging in a different probe. Depending on the type of AS-active probe fields from a few nano Tesla up to 12 Tesla can be measured. Further information can be found in the data sheet of the AS-active probes.

Table 1 shows the measurement ranges as well as the transfer factors for the analog output resulting from the different probes.

class	ranges and transfer factors with AS-probe adapter range x5, x50		
High:	x5	⁽¹⁾ 20 T	10 V / 20 T
	x50	2 T	10 V / 2 T
Normal:	x5	2000 mT	10 V / 2000 mT
	x50	200 mT	10 V / 200 mT
Low:	x5	200 mT	10 V / 200 mT
	x50	20 mT	10 V / 20 mT
Ultralow:	x5	200 μT	10 V / 200 μT
	x50	20 μT	10 V / 20 μT

Table 1

(1) calibrated up to 12 T

Included in delivery is an adapter cable which allows the easy connection of the 15-pole SubD connector of the AS-active probes with the screw terminals of the AS-probe adapter.

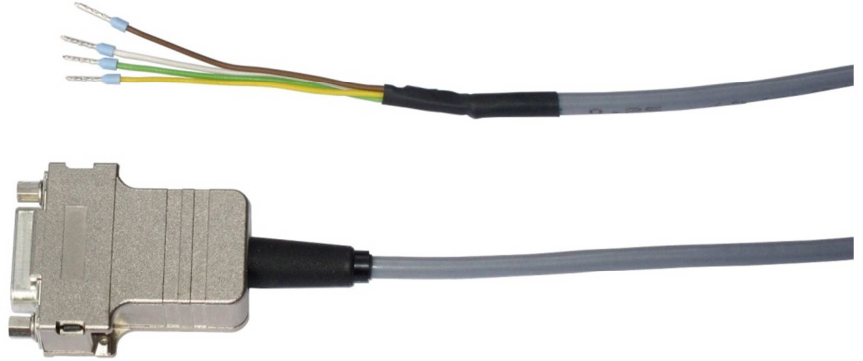

Attention should be paid that there is a connection between GND and cable shield as well as the connector housing in the adapter cable. At brass probes this is also connected to GND. Possibly an isolated installation of the probe and the connector is necessary to prevent an unintended connection between measuring GND and protective earth.

Technical Data for AS-probe adapter (without AS-active probe):

Supply

supply voltage	9 V – 36 V DC
power consumption	<1.5 W
output voltage probe supply	±3 V
output current probe supply	max. 20 mA

Signal

gain	switchable x5, x50
offset at output	at x5: <±0.25 mV (at 23°C) at x50: <±2.5 mV (at 23°C)
offset drift at output	at x5: <0.025 mV/K at x50: <0.25 mV/K
gain error	typ. ±0.1 %, max. ±0.4 % (DC at 23°C)
gain drift	typ. ±0.005 %/K
input voltage range	at x5: ±2 V at x50 ±0.2 V
input resistance	22 kΩ
output voltage	±10 V
output current	max. 2 mA to keep specification
load resistance	min. 5 kΩ to keep specification
short-circuit proof	yes
output resistance	<1 Ω
bandwidth (-3 dB)	100 kHz depends also on the used probe

Isolation

galvanic isolation	power supply – signal: 100 VDC, 70 VAC with varistor protection
--------------------	--

Mechanics

case	Phoenix COMBICON DIN rail housing, width 20 mm
operating temperature	+5°C to +50°C
storage temperature	-10°C to +50°C

Adapter Cable for Probe Connection

connector	probe side: 15-pole SubD socket adapter side: 4 single leads
set-up	4-pole, screened screen and socket housing connected to analog ground!
length	5 m



Included in Delivery:

- AS-probe adapter
- 5 m adapter cable for probe connection
- operating manual
- factory calibration certificate

Options:

- 9 V plug-in power supply unit für AS-probe adapter
- different gain factors
- adapter cable with different length

Application Notes

On our website (<http://www.projekt-elektronik.com/applikation.php>) under Application you can find many additional documents with information, hints and examples for measuring of magnetic fields.

Questions?

Do you have any question about a measuring task? Call us, we would be pleased to advice you.

As manufacturer of this system we can fulfill your desires about developing AS-active probes, changing of measurement range, changing of gain factors or other needs. Please call us or send us an email.

Gladly we accept your suggestions,

your PE – Team.